

Sawmills

ADA Transition Plan



Adopted on November 19, 2024

TABLE OF CONTENTS

	EXECUTIVE SUMMARY	3
	TITLE II OF THE AMERICAN WITH DISABILITIES ACT OF 1990 (ADA)	3
	SECTION 504 OF THE REHABILITATION ACT OF 1973	4
	TOWN OF SAWMILLS ADA PROGRAM	5
	SAWMILLS GRIEVANCE PROCEDURE	5
	WESTERN PIEDMONT COUNCIL OF GOVERNMENTS ADA WEBSITE FOR Sawmills	6
	POPULATION WITH A DISABILITY OR FUNCTION DIFFICULTY ANALYSIS	6
	ANALYSIS STUDY AREA	7
	ANALYSIS METHODOLOGY	7
	ANALYSIS STUDY RESULTS	8
	FACILITY ASSESSMENT INTRODUCTION	14
	FACILITY ASSESSMENT PRIORITIES	14
	FACILITY ASSESSMENT METHODOLOGY	15
	FACILITY ASSESSMENTS	16 - 31
	ADA COMPLIANCE IN PLAY AREAS	32 - 33
	PLAY AREA ASSESSMENTS	34 -45
	PEDESTRIAN RIGHT OF WAY COLLECTOR APPLICATION	46
	PEDESTRIAN RIGHT OF WAY METHODOLOGY	46
	INTRODUCTION TO COLLECTOR APPLICATION CATEGORIES AND TECHNICAL STANDARDS	53
	PROBLEMATIC AREAS WITHIN THE PEDESTRIAN RIGHT OF WAY	54 - 65
	COST ESTIMATES	66 - 75
	REFERENCES	76
	PUBLIC COMMENTS	76
	APPENDICES	76



EXECUTIVE SUMMARY

Cities with many pedestrian barriers can inhibit community mobility, access to services, and social participation for people with disabilities. Creating an inventory and plan of action for removing pedestrian barriers within municipalities is a crucial step to creating a more accessible environment for all. The primary purpose of this study is to prepare a plan, titled ADA Transition Plan, for the Town of Sawmills in accordance with two civil rights legislations:

1. Americans with Disabilities Act of 1990 (ADA), Title II Regulations, Nondiscrimination on the Basis of Disability in State and Local Government Services, 28 CFR Part 351 , and
2. Section 504 of the Rehabilitation Act of 1973, as amended, Nondiscrimination on the Basis of Disability in Programs or Activities Receiving Federal Financial Assistance, 49 CFR Part 27.

The intent of the ADA Title II regulations is to ensure nondiscrimination and access for individuals with disabilities in State and local government services. The intent of the Section 504 regulations is to prohibit discrimination on the basis of disability in programs or activities receiving Federal financial assistance.

This report will identify barriers within municipally owned buildings as well as barriers within the pedestrian right of way. The pedestrian right of way includes any infrastructure meant for pedestrian utilization. Mobility hazards are identified during walking audits and documented in a Pedestrian Right of Way Collector Application. The application collects a broad range of data and has criteria for sidewalks, curb ramps, driveway cuts, intersections, railroad crossings, bus stops, crosswalks, and pedestrian islands.

Town of Samills is required to conduct a self-assessment and to establish a transition plan (28 CFR 35.105-35.107). All ADA efforts have been based on the appropriate guidelines for the project at hand. The pedestrian right of way inventory collection process (mentioned above) utilizes the United States Access Board's Proposed Right-of-Way Accessibility Guidelines (PROWAG). The facility inventory produced by an external contractor utilized a checklist which was based on the 2010 ADA Standards for Accessible Design.

We look forward to our continued progress in achieving the objectives of Section 504 of the Rehabilitation Act of 1973, the Americans with Disabilities Act of 1990, and the ADA Amendments Act of 2008.

TITLE II OF THE AMERICANS WITH DISABILITIES ACT OF 1990 (ADA)

Title II applies to State and local government entities, and protects qualified individuals with disabilities from discrimination on the basis of disability in services, programs, and activities provided by State and local government entities. Title II extends the prohibition on discrimination established by section 504 of the Rehabilitation Act of 1973, as amended, 29 U.S.C. 794, to all activities of State and local governments regardless of whether these entities receive Federal financial assistance.

State and local governments are required to follow specific architectural standards in the new construction and alteration of their buildings. They also must relocate programs or otherwise provide access in inaccessible older buildings, and communicate effectively with people who have hearing, vision, or speech disabilities. Public entities are not required to take actions that would result in undue financial and administrative burdens. They are required to make reasonable modifications to policies, practices, and procedures where necessary to avoid discrimination, unless they can demonstrate that doing so would fundamentally alter the nature of the service, program, or activity being provided.

SECTION 504 OF THE REHABILITATION ACT OF 1973

Section 504 of the 1973 Rehabilitation Act was the first disability civil rights law to be enacted in the United States. It prohibits discrimination against people with disabilities in programs that receive federal financial assistance, and set the stage for enactment of the Americans with Disabilities Act. Section 504 works together with the ADA and IDEA to protect children and adults with disabilities from exclusion, and unequal treatment in schools, jobs and the community.

TOWN OF SAWMILLS ADA PROGRAM

Sawmills contracted with Western Piedmont Council of Governments (WPCOG) to identify mobility barriers and create a plan of action for town owned and sponsored services, events, buildings, and pedestrian infrastructure. The following was included in the scope of services:

- Inventory Collection: Create database for municipally owned facilities, parking lots, sidewalks, curb ramps, driveway cuts, intersections, railroad crossings, bus stops, crosswalks, and pedestrian islands
- Reporting to Town/DOJ (when necessary)/ADA Specialists in accordance to the US Access Board
- Cost Analysis/Estimate to Correct Non-Compliant Areas – this is an estimation of materials and excludes labor costs
- Transition Plan: Coordination of the Town’s Capital Improvements Plan and the site evaluation survey to establish High / Medium /Low Impact Areas to be corrected
- Maintenance of all Changes/Improvements to Documents: Inventory List, Reports, Transition Plan, support for changes to website, and any filed grievances

SAWMILLS GRIEVANCE PROCEDURE

In accordance with the requirements of title II of the Americans with Disabilities Act of 1990 (“ADA”), Sawmills will not discriminate against qualified individuals with disabilities in its services, programs, or activities.

Employment: Sawmills does not discriminate based on disability in its hiring or employment practices and complies with all regulations promulgated by the U.S. Equal Employment Opportunity Commission under title I of the ADA.

Effective Communication: Sawmills, upon request, will provide appropriate aids and services for effective communication for qualified persons with disabilities. Effective communication is essential in the equal participation of Sawmills programs, services, and activities. Available aids and services include qualified sign language interpreters, documents in Braille, and other ways of making information and communications accessible to people who have speech, hearing, or vision impairments.

Modifications to Policies and Procedures: Sawmills will make all reasonable modifications to policies and programs to ensure that qualified individuals with disabilities have an equal opportunity to participate in all of its programs, services, and activities. This applies to service animals and other services as requested.

Anyone who requires an auxiliary aid should contact the office of the ADA Coordinator, Averi Ritchie, at or (828) 514-5200, as soon as possible, but no later than 72 hours before the scheduled event. Auxiliary aid includes services for effective

communication, or a modification of policies or procedures to participate in a program, service, or activity of the Sawmills. Individuals with registered service animals only need to provide notice if event accommodations are necessary.

The ADA does not require Sawmills to take any action that would fundamentally alter the nature of its programs or services, or impose an undue financial or administrative burden.

Grievances involving accessibility restrictions for persons with disabilities, that will be utilizing Sawmills programs, services, or activities; are handled by the ADA Coordinator, Averi Ritchie, at (828) 514-5200.

Sawmills will not place a surcharge on persons with disabilities to cover the cost of providing auxiliary aids/services or reasonable modifications of policy. This includes retrieving items from locations that are open to the public but are not accessible to persons who use wheelchairs.

WESTERN PIEDMONT COUNCIL OF GOVERNMENTS ADA WEBSITE FOR SAWMILLS

While WPCOG does not maintain the ADA portion of Sawmills's website, it does serve to provide support and guidance in posting necessary documents. WPCOG's ADA webpage includes a subset for Sawmills documents as well as ADA guidance and legislative updates. All adopted grievance documents and Transition Plans are posted to this subset.

POPULATION WITH A DISABILITY OR FUNCTION DIFFICULTY ANALYSIS

In planning for accessibility, analyzing data for communities with disabilities or function difficulty will better allow the town of Sawmills to assess and plan for eliminating mobility barriers. The United States Census "attempts to capture six aspects of disability: (hearing, vision, cognitive, ambulatory, self-care, and independent living); which can be used together to create an overall disability measure, or independently to identify populations with specific disability types." Source: United States Census.

In 2008, the Census introduced new questions regarding "aspects of disability" to their American Community Survey questionnaires. The questions cover the six disability types to gauge disability status throughout each census tract. Each disability type, as defined by the Census, can be found below:

- Hearing difficulty--deaf or having serious difficulty hearing.
- Vision difficulty--blind or having serious difficulty seeing, even when wearing glasses.
- Cognitive difficulty--Because of a physical, mental, or emotional problem, having difficulty remembering, concentrating, or making decisions.
- Ambulatory difficulty--Having serious difficulty walking or climbing stairs.
- Self-care difficulty--Having difficulty bathing or dressing.

- Independent living difficulty--Because of a physical, mental, or emotional problem, having difficulty doing errands alone such as visiting a doctor's office or shopping. Source: US Census

An analysis was performed using Census social characteristics data to examine disability and function difficulty conditions within Town of Sawmills town limits. This analysis aims to note concentrated areas of Sawmills population reported as having a disability. These areas must be identified to give special consideration to existing pedestrian and town managed facility placement within these areas. The analysis methodology and results are discussed in this section.

ANALYSIS STUDY AREA

This analysis utilized the 2020 Census Tracts. Census Tracts are small, relatively permanent statistical subdivisions of a county. Caldwell County Census Tracts that intersect the Sawmills town limits make up the analysis study area. This area includes the combined size of Tracts 306, 307, 312.02, 314.01, 314.02 and 314.03 as illustrated in Map 1. The location of these Tracts is in the center and the southeastern corner of Caldwell County, which totals approximately 54 square miles in size. Sawmills town limits intersect Tracts 306, 307, 314.01 and 314.03. Small sectors of Sawmills intersect Tracts 312.02 and 314.02, which were also included in the analysis.

ANALYSIS METHODOLOGY

The following methodology explains how Census Tract percentages were determined:

1. United States Census and 2016-2020 American Community Survey (ACS) 5-Year data were used to calculate Caldwell County hearing difficulty, vision difficulty, cognitive difficulty, ambulatory difficulty, self-care difficulty, and independent living difficulty

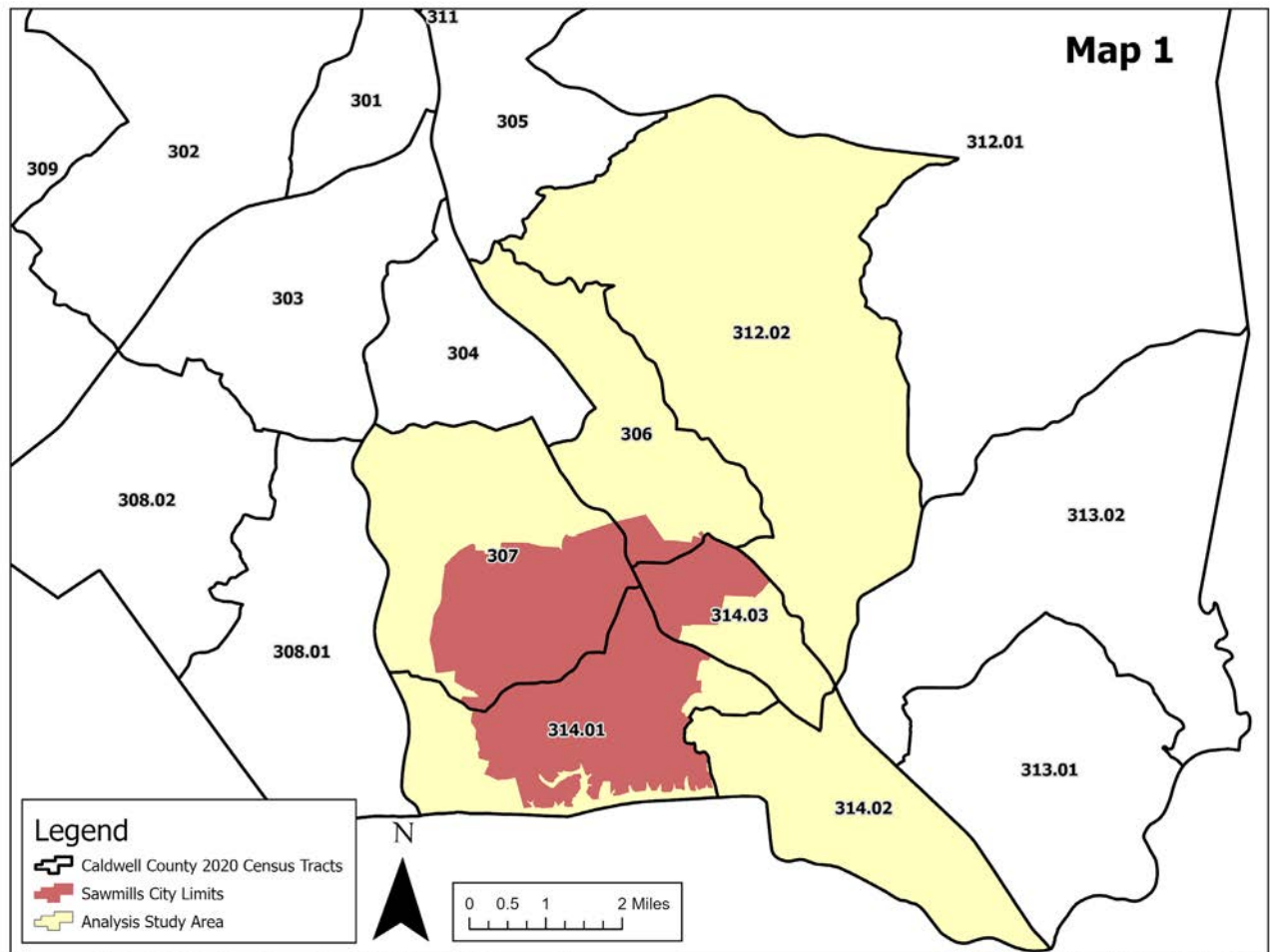

This map was created on December 4, 2023 and is a graphic representation and should only be used for illustrative purposes. Maps created with data provided by WPCOG Planning departments, Caldwell County GIS, and ESRI.

Project File Path: Q:\Planning\Andrew_Webb\Transportation\ADA\ADA.aprx

percentages. Percentages were calculated by dividing the total civilian noninstitutionalized population with a disability by the total civilian noninstitutionalized population. The Census defines the civilian noninstitutionalized population as “all U.S. civilians not residing in institutional group quarters facilities such as correctional institutions, juvenile facilities, skilled nursing facilities, and other long-term care living arrangements.”

2. The same Census and ACS data were used to calculate Census Tract level population percentages. The method used in step 1 was repeated in step 2 on a more area-specific scale. Percentages were derived by dividing the Tract's total civilian noninstitutionalized population with a disability by the total civilian noninstitutionalized population.
3. Sawmills disability status averages were then compared with overall Caldwell County disability status averages to determine concentration levels throughout each Tract. Census Tract level total civilian noninstitutionalized population with a disability percentage exceeding the County's average disability status population percentages were scored and placed into a 4-level concentration scale based on the six difficulty types (hearing, vision, cognitive, ambulatory, self-care, and independent living).
 - a. No Concentration – Census Tract with zero types exceeding County disability status averages.
 - b. Low Concentration – Census Tract with one to two types exceeding County disability status averages.
 - c. Moderate Concentration – Census Tract with three to four types exceeding County disability status averages.
 - d. High Concentration – Census Tract with more than four types exceeding County disability status averages.
4. The Sawmills managed facility locations and sidewalk networks were then mapped and overlaid onto the study area. Percentages were calculated to show how many facilities and how much sidewalk exists within the high and low disability population areas.

ANALYSIS STUDY RESULTS

Table 1 shows the total civilian non-institutionalized population for Caldwell County Tracts and their total civilian noninstitutionalized population with disability percentages. The Caldwell County percentages create the baseline for the concentration scores. Table 2 shows where the Tracts land on the concentration scale and their disability averages exceeding the County averages.

For Caldwell County, approximately 10.7% percent of the population with a disability status have an ambulatory difficulty. Ambulatory difficulties are the most prevalent disability type in the County, followed by independent living difficulty (8.3%), cognitive difficulty (7.8%) and hearing difficulty (4.5%). Approximately 4,385 of Caldwell County's noninstitutionalized residents (3.8%) have a self-care difficulty. Equally 4,385 of Caldwell County's noninstitutionalized residents (3.8%) have vision difficulty. Self-care difficulty & vision difficulty dually represent the County's smallest percentage of disability types.

Table 1 Percentages of Civilian Non-institutionalized Population with a Disability of Function Difficulty

Geography	Total Civilian Noninstitutionalized Population	% Hearing Difficulty	% Vision Difficulty	% Cognitive Difficulty	% Ambulatory Difficulty	% Self-Care Difficulty	% Independent Living Difficulty
Caldwell County	81,205	4.5%	3.8%	7.8%	10.7%	3.8%	8.3%
Census Tract 301	5,697	0.7%	1.5%	7.2%	9.4%	1.9%	2.7%
Census Tract 302	5,027	5.2%	3.9%	8.6%	6.6%	3.1%	7.0%
Census Tract 303	4,057	3.4%	3.6%	9.4%	12.9%	6.0%	11.4%
Census Tract 304	3,482	4.9%	4.6%	9.1%	15.8%	5.1%	8.1%
Census Tract 305	4,946	5.0%	2.4%	5.6%	16.4%	3.6%	15.9%
Census Tract 306	4,350	4.1%	3.4%	6.2%	9.8%	3.4%	7.2%
Census Tract 307	6,986	5.7%	3.4%	14.1%	15.2%	6.1%	11.0%
Census Tract 308.01	3,180	5.8%	2.2%	4.1%	10.1%	2.7%	8.7%
Census Tract 308.02	3,727	5.4%	8.6%	10.6%	16.8%	4.9%	7.5%
Census Tract 309	4,919	4.5%	4.3%	5.6%	7.2%	4.0%	5.4%
Census Tract 310	3,352	5.8%	3.5%	9.9%	11.3%	1.5%	9.1%
Census Tract 311	4,584	7.0%	2.4%	6.2%	7.7%	3.4%	5.3%
Census Tract 312.01	3,777	4.9%	2.8%	10.1%	11.4%	5.1%	12.5%
Census Tract 312.02	4,838	7.5%	11.2%	9.2%	9.3%	4.6%	4.5%
Census Tract 313.01	4,790	1.5%	1.5%	6.0%	4.5%	0.7%	5.6%
Census Tract 313.02	4,309	5.4%	3.0%	4.7%	6.9%	2.4%	7.1%
Census Tract 314.01	3,360	2.4%	6.2%	3.6%	13.1%	4.4%	9.2%
Census Tract 314.02	3,468	3.1%	2.5%	6.6%	10.9%	7.1%	11.6%
Census Tract 314.03	2,356	3.1%	2.7%	5.4%	9.5%	1.2%	8.6%

Table 2 Concentration Scale Results - Tracks Averages Higher / Lower Than County Averages

Geography	Concentration Level	% Hearing Difficulty	% Vision Difficulty	% Cognitive Difficulty	% Ambulatory Difficulty	% Self-Care Difficulty	% Independent Living Difficulty
Census Tract 306	None	Lower	Lower	Lower	Lower	Lower	Lower
Census Tract 307	High	Higher	Lower	Higher	Higher	Higher	Higher
Census Tract 312.02	Moderate	Higher	Higher	Higher	Lower	Higher	Lower
Census Tract 314.01	Moderate	Lower	Higher	Lower	Higher	Higher	Higher
Census Tract 314.02	Moderate	Lower	Lower	Lower	Higher	Higher	Higher
Census Tract 314.03	Low	Lower	Lower	Lower	Lower	Lower	Higher

Table 3 Sawmills Facilities

Facility Name	Facility Type	Census Tract Concentration Level
Public Works	Public Works	None
Sawmills Town Hall	Town Hall	Low
Farmer's Market	Farmer's Market	High
Recreation Department	Recreation	None
Baird Park	Park	None
Veteran's Park	Park	Moderate
Sawmills Fire Department	Fire Department	Low

Map 2 shows where each Census Tract falls on the 4-Level concentration scale. Five of the six Census Tracts had at least one disability type exceeding County disability status averages. Ambulatory and independent living difficulties are the two highest disability averages in the study area. Four of the Tracts have higher averages than the County where hearing and vision statuses had only two Tracts higher than their respective county baselines—making them the lowest concentration of civilian noninstitutionalized population with a disability.

The most concentrated Census Tract is 307. This Tract is 9.95 square miles in size and makes up 5.42% of the study area. Tract 307 is the second largest (in size) of the six tracts. It has five averages higher than the County disability status averages. There are an estimated 1,062 persons of its total civilian noninstitutionalized population (6,986) with an ambulatory disability (15.2%). Approximately 238 persons within the Tract have a vision disability (3.4%). Vision disability was the only difficulty where tract 307 fell below the County's status average.

Tracts 312.02, 314.01, and 314.02 are moderately concentrated Tracts. Tracts 312.02 & 314.01 have four averages higher than the County disability status averages. Tract 314.02 has 3 averages higher than the County disability status averages, these three tracts makeup 64.8% of the study area. Approximately 542 people (11.2%) in Tract 312.02 (the second largest in civilian noninstitutionalized population) have vision difficulty, 9.2% are reported as having cognitive difficulty (1.2% higher than the County's baseline), and around 363 people have hearing difficulty (3% more than the County's baseline). Tract 314.02 had the highest percentage of independent living difficulty among the six tracts. Approximately 458 (13.1%) of the Tract's 3,468 civilian noninstitutionalized population reported ambulatory difficulty, and 215 (6.2%) have a vision disability. Over thirteen percent of 314.01's people have an ambulatory difficulty (around two and a half percent higher than the 10.7% County baseline). Approximately 148 people (4.4%) have a self-care disability, which is slightly over half of a percent higher than the County's self-care average.

The low concentration level consists solely of Tract 314.03, which represents the smallest space (17.9%) within the study area. Approximately 203 people (8.6%) experience difficulties with independent living, which is 0.3% higher than Caldwell County's average. Tract 306 has an area of 6.03 square miles and a population of 4,350 people, this tract is unique due to it having no concentration level. The survey revealed that this tract had lower than county baseline averages for all six of the disabilities referenced.

The seven Sawmills town facility locations are shown in Map 2. Table 3 lists the facilities per Census Tract concentration level. All buildings, parking lots, and parks exist within four Tracts. One of these facilities, the Farmer's Market, has an address within the high-concentrated Tract 307. Veterans Park resides within the moderate concentration tract 314.01. Two facilities have addresses inside the low-concentration tract 314.03, namely Sawmills Town Hall and Sawmills Fire Department. The remaining three facilities are contained inside Tract 306, which has no concentration level. The facilities inside Tract 306 include Public Works, Baird Park, and the Recreation Department.

The Town of Sawmills has 11.7 miles of sidewalk, as shown in Map2, dispersed between five of the six Census Tracts. Sidewalks can be found in Tracts 306, 307, 314.01, 314.02, and 314.03, but not in Tract 312.02. Table 4 provides information on where the sidewalk runs parallel to roadways within these Tracts. In the highly concentrated Tract 307, approximately 0.4 miles of sidewalk exist. The majority of the sidewalk network, totaling 6.2 miles, was constructed within moderately concentrated Tracts, which include Tracts 312.02, 314.01, and 314.02. The remaining 5.2 miles of sidewalk are divided between two tracts. Tract 314.03, classified as low concentrated, has exactly 2 miles of sidewalk, while Tract 306, which has no concentration, contains 3.2 miles of sidewalk.

In conclusion, the Town of Sawmills exhibits several concentrations, ranging from low to high, of the civilian noninstitutionalized population with reported disabilities or function difficulties. The study area comprises three moderately concentrated tracts, one low concentrated tract, one no concentration tract and one high concentrated tract. Out of the six tracts, four had higher averages for self-care and independent living compared to Caldwell County, while four had lower averages for vision. Sawmills downtown experiences a divide between high, moderate, and low concentrated tracts. Based on the concentration levels, it is advisable to prioritize the consideration of updated pedestrian facilities in areas with higher reported disabled populations, specifically Census Tract 307 and 314.01. By eliminating mobility barriers and improving connectivity within the town limits, both the town and its citizens will be protected.

Table 4 Sawmills Sidewalks

Geography	Concentration Level	Existing Sidewalk (in Miles)
Census Tract 306	None	3.2
Census Tract 307	High	0.4
Census Tract 312.02	Moderate	N/A
Census Tract 314.01	Moderate	2.5
Census Tract 314.02	Moderate	3.7
Census Tract 314.03	Low	2.0
Study Area	(x)	11.7

Map 2

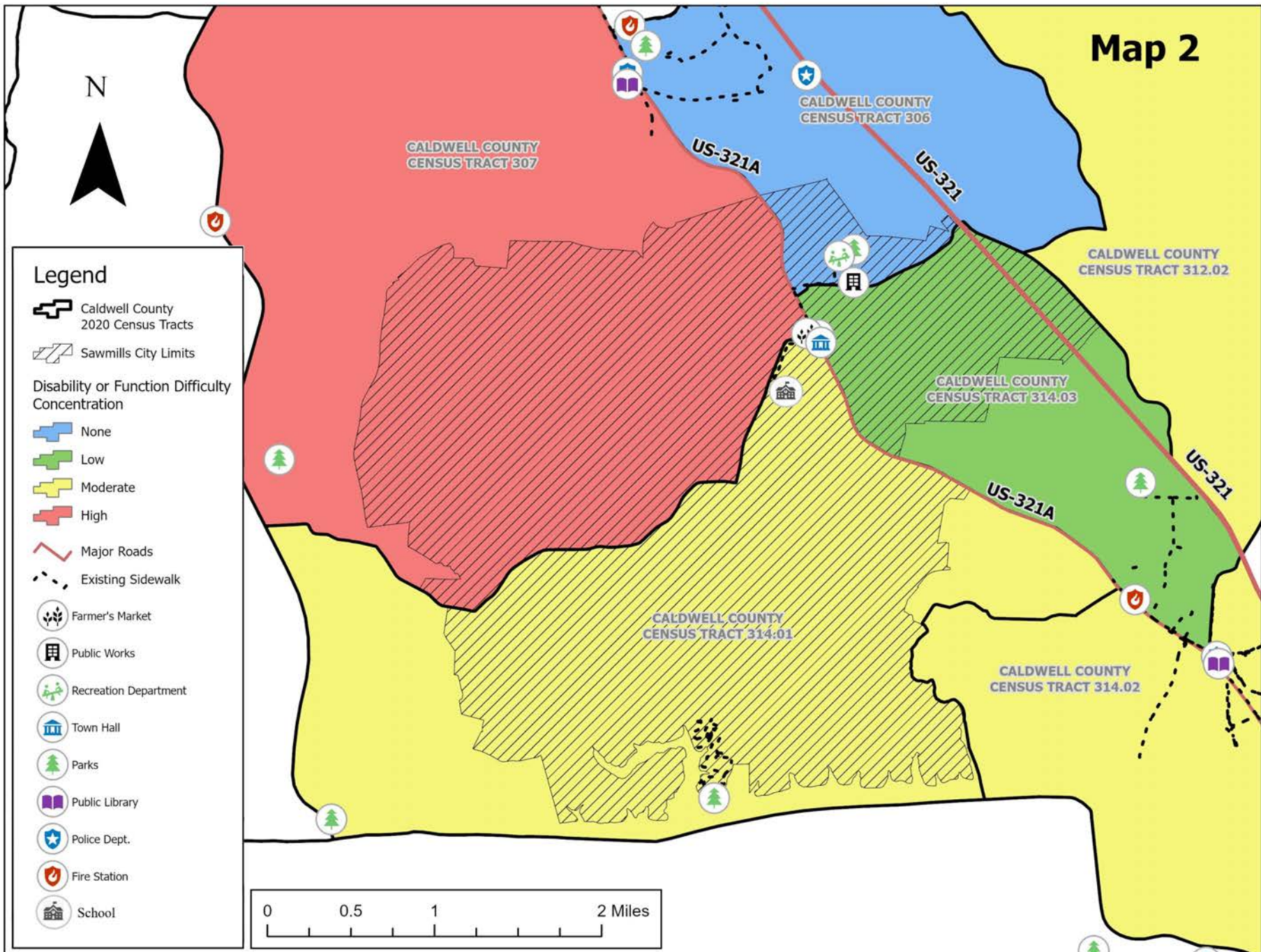

This map was created on December 15, 2023 and is a graphic representation and should only be used for illustrative purposes. Maps created with data provided by WPCOG Planning departments, Caldwell County GIS, and ESRI.

Project File Path*Q:\Planning\Andrew_Webb\Transportation\ADA\ADA.aprx

FACILITY ASSESSMENT INTRODUCTION

As mentioned above, Title II of the ADA only impacts municipally owned facilities. This title does not address employment or issues concerning other sections of the ADA.

Although many situations allow issues of accessibility to be resolved by changes to program accommodation, there are situations where access to programs, services and activities can only be achieved by removal of physical barriers. This report identifies such physical barriers within each building and from the nearest public way and/or accessible parking space(s) to each building.

Relative to Program Access as stipulated in Title II, state and local governments/agencies, "Are not required to take any action that would result in the fundamental alteration in the nature of the service, program, or activity or in undue financial and administrative burdens. However, public entities must take any other action, if available, that would not result in a fundamental alteration or undue burdens but would ensure that individuals with disabilities receive the benefits or services."

Many think that only new construction and alterations need to be accessible and that older facilities are "grandfathered". However, because the ADA is a civil rights law and not a building code, older facilities are often required to be accessible to ensure that people with disabilities have an equal opportunity to participate.

Sawmills contracted with Western Piedmont Council of Governments (WPCOG) to address remaining ADA needs within Sawmills. Sawmills, in conjunction with WPCOG, has identified 21 facilities that either are municipally-owned or have heavy use regarding town sponsored programs and services open to the public.

This report was prepared for Sawmills as part of an effort to:

1. Comprehensively document elements of the built environment which negatively impact individuals with disabilities, and
2. Plan for most important facility improvements in conjunction with the 2010 ADA Standards for Accessible Design. Included in Appendix A.

FACILITY ASSESSMENT PRIORITIES

This report's ADA compliance information is organized to follow the three priorities for barrier removal as recommended by the Department of Justice in the ADA Title II regulations.

The three priorities are included and color coded as follows:

- **RED Priority 1 (High):** Accessible Approach and Entrance
- **ORANGE Priority 2 (Moderate):** Access to goods and services and access to public toilet rooms
- **GREEN Priority 3 (Low):** Access to other items such as water fountains and public telephones
-

- **BLUE Technically Infeasible or Not Applicable:** Certain standards do not apply to facilities built prior to March 15, 2012. These items have been noted and do not need to be corrected unless the facility is altered. Measurements within a reasonable tolerance range that would involve undue burden to correct and structural or financial infeasibility are covered under technically infeasible.

Red Priority 1 (High) items are more time sensitive mobility barriers that should be corrected first. According to regulations, these items are most unsafe or present more immediate liabilities for municipalities. **Green Priority 3 (Low)** items are less time sensitive. The following methodology is a modified version of the ADA National Network Guidelines (found in Appendix A). This report is meant to be a living document. Sawmills' Public Works Department and/or Engineer review is warranted to document any corrected or technically infeasible items.

FACILITY ASSESSMENT METHODOLOGY

The survey team relied on guidelines approved by the ADA National Network while inventorying facilities and certain items within the pedestrian right of way. The resulting methodology correlates with the methodology found in the facility survey guidelines. A facility survey can be found in Appendix A.

High/Critical Priority – relating to immediate safety hazards or access to a facility. Without proper facility access, the categories below become null. Overall interior and exterior door pressures and closure times are high priorities. Exterior doors relate directly to access to a facility as well as most interior doors. Some interior doors relate more to access to goods and services, however, for consistency, doors are scored using the same criteria. There are no set standards for exterior door pressures, but no more than 10 pounds is recommended. Interior doors have a required pressure of 5 pounds or less. Both interior and exterior doors door closure times cannot take less than 5 seconds to close from a 90 degree open position to 12 degrees from the door latch.

Moderate Priority – relating to less severe safety hazards or access to goods and services and public restrooms (certain issues within service areas or public restrooms may still fall into high or low categories depending on the severity of the issue)

Low Priority – relating to non-compliant issues that do not pose an immediate safety hazard or access to an accessory (items such as water fountains and public telephones). Most items received a “low” score if only 5” or less out of compliance in facilities

Not applicable/technically infeasible – This could be due to changing standards, measurements within a reasonable tolerance range, structural or financial infeasibility, etc.

****Note:** High, moderate, and low recommendations are included in the plan for consideration. Recommendations are not based on standards and, therefore, are not required.

Sawmills Parks & Recreation Dept.

General Observations & Recommendations

Notes: All areas open to the public must have access aisles that are at least 36" wide. Rest areas must be present in the front waiting area as well as in offices open to the public. Rest areas must be 33" wide by 48" deep if entered from the front or rear.

High Priority	Moderate Priority	Low Priority
» n/a	» n/a	<ul style="list-style-type: none"> » Threshold coming in at the exterior door could become a trip hazard. Thresholds cannot be higher than ¼" high. <ul style="list-style-type: none"> » Note: The threshold can be ½" high with the top ¼" beveled to be no steeper than 1:2 if the threshold was installed on or after the 1991 ADA Standards went into effect. » Or no more than ¾" high with the top ½" beveled no steeper than 1:2 if the threshold was installed before the 1991 ADA Standards went into effect on January 26, 1993.

Moderate Recommendation
» Signage stating "Employees Only" is recommended for any sections of the building not open to the public.
Currently, there are no High or Low Recommendations

Technically Infeasible or Not Applicable (due to changing standards or measurements within tolerance range)
» n/a

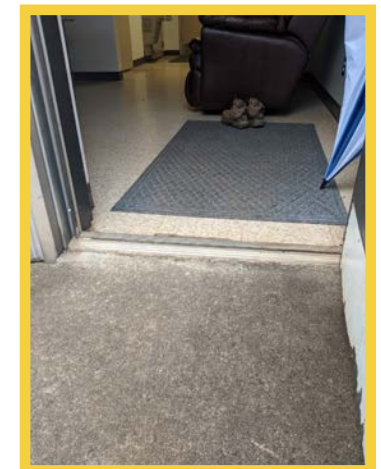

Threshold coming in at the exterior door could become a trip hazard.

Parking

*There should be 1 accessible space for every 25 parking spaces. 1 of every 6 accessible spaces should meet the dimensions of a van accessible space and should be marked accordingly.



Need designated accessible parking with signage and striped access.

High Priority	Moderate Priority	Low Priority
<ul style="list-style-type: none"> » Accessible parking space must have a designated space and striped access aisle. » A new accessible parking space sign is needed. The sign must be posted 60" high to the base and must be marked van accessible. 	» n/a	» n/a
Technically Infeasible or Not Applicable (due to changing standards or measurements within tolerance range)		Currently, there are no High, Moderate or Low Recommendations
» n/a		

Door Pressures

High Priority	Moderate Priority	Low Priority
<ul style="list-style-type: none"> » Exterior Door (Main Entrance) <ul style="list-style-type: none"> » Push Pressure: 11 pounds of force (within acceptable range) » Pull Pressure: 11 pounds of force (within acceptable range) » Closure Time: 3.92 seconds (high) 	» n/a	» n/a
Bathroom Door <ul style="list-style-type: none"> » Push Pressure: 6 pounds of force (within acceptable range) » Pull Pressure: 6 pounds of force (within acceptable range) » Closure Time: not self-closing 	Technically Infeasible or Not Applicable (due to changing standards or measurements within tolerance range)	Currently, there are no High, Moderate or Low Recommendations
	» n/a	

Bathroom

High Priority	Moderate Priority	Low Priority
<ul style="list-style-type: none"> » The towel dispenser is mounted 63" high and is blocked by the sink – ADA Standards require that the operable parts of the hand dryer or towel dispenser must be no higher than 44" when located above a sink or countertop between 20-25" deep OR no higher than 48" above the floor when not located above an obstruction. 	<ul style="list-style-type: none"> » Signage for the restroom should be in Braille and mounted on the latch side of the door at the heights designated in Appendix A Priority 3 – Toilet Rooms. <ul style="list-style-type: none"> » Due to the water fountain, a sign on the opposite side of the door would be required. » Pipes should be insulated under the sink. » The toilet paper dispenser is located 17" from the front of the toilet – ADA Standards require that toilet paper dispensers should be located between 7-9" from the front of the toilet to the centerline of the dispenser. 	<ul style="list-style-type: none"> » Light switch is located 50" high – operable parts can be no higher than 48"

Technically Infeasible or Not Applicable
(due to changing standards or measurements within tolerance range)

» n/a

Currently, there are no High, Moderate or Low Recommendations



Pipes should be insulated



Signage should be in Braille and mounted on the latch side of the door at regulation height.



Toilet paper dispenser needs to be closer to the toilet.

Sawmills Town Hall

Questions and Key Notes

High Priority

- » There are currently steps throughout Town Hall and no accessible route around them. The restroom and several offices are not accessible. There must be an accessible route to all elements open to the public.
 - » The back employee entrance may be a temporary option as an accessible route to the restroom and back offices. For use, the entrance cannot be locked and signage (please see accessible entrance sign below) would need to be added to the back entrance. A striped access aisle would need to connect accessible parking to the door. This would only be a temporary fix since the restroom and back offices can only be entered from the outside of the building. Future public spaces should allow equal access to all citizens. Accessible routes should not involve extra effort for those with function difficulties.
- » All accessible exterior entrances open to the public must be marked with the international symbol of accessibility. Inaccessible entrances must have signage for the nearest accessible entrance.
- » Inside the building, all exits must be signed (and in Braille). Please follow Priority 2 – Access to Goods and Services for proper height requirements. (Appendix A)
- » Fire alarm systems must have both flashing and audible signals.
- » Several doorways throughout Town Hall were too narrow (30" wide). Doorways must be at least 32" wide, and adjoin accessible routes at least 36" wide.
- » • An accessible parking space must be present that is also van accessible. The current accessible space fits the dimensions of a van accessible space. However, there is no signage for the van accessible space. A sign must be present that is 60" high from the ground to the bottom of the sign. It must include the accessible symbol as well as the words "van accessible". The current sign does not include van accessible language and is only 46" high

Moderate Priority

- » Inside the building, all permanent rooms must have signage (and in Braille). Please follow Priority 2 – Access to Goods and Services for proper height requirements. (Appendix A)

Low Priority

- » The current space has the following cross and running slopes: (low/ technically infeasible due to cost for all parking lot measurements)
 - » Top of space: 3.3% cross slope
 - » Middle of space: 3% cross slope
 - » Bottom of space: 3.3% cross slope
 - » All running slopes were below 2% and met standards
- » The access aisle has the following cross and running slopes:
 - » Top of aisle: 3% cross slope
 - » Middle of aisle: 3.5% cross slope
 - » Bottom of aisle: 3.8% cross slope
 - » All running slopes were below 2% and met standards
- » The cross slope of the accessible parking area were only slightly out of compliance. This would be considered a low priority item.

Questions and Key Notes Cont.

Note: **The running slope and cross slope of each accessible space and accessible aisle is measured at the top (area closest to the concrete parking block), middle, and bottom. According to ADA Standards, the slope of accessible parking spaces and access aisles should be no greater than 2% in all directions.

Technically Infeasible or Not Applicable
(due to changing standards or measurements within tolerance range)

» n/a

Currently, there are no High, Moderate or Low Recommendations



There are currently steps throughout Town Hall and no accessible route around them.

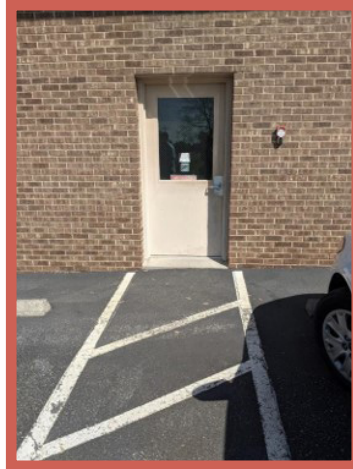

The back employee entrance may be a temporary option as an accessible route

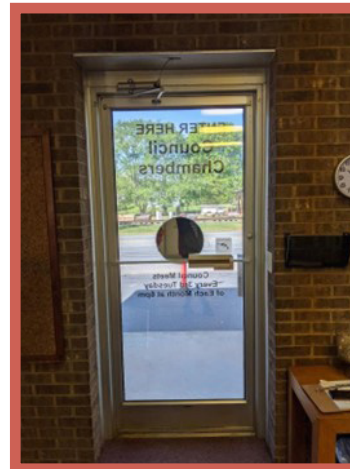

Several doorways throughout Town Hall were too narrow.

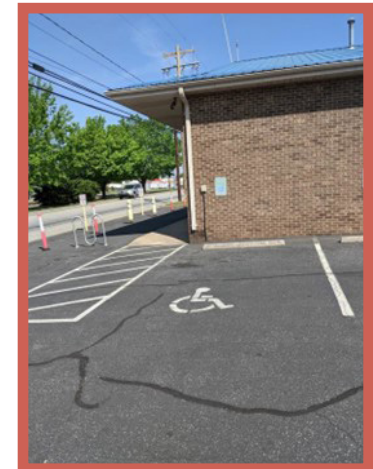

An accessible parking space must be present that is also van accessible.



Inaccessible entrances must have signage for the nearest accessible entrance.

Front Lobby

Note **Recommend signage stating “Employees Only” on the door that requires buzzer access. Members of the public can always request meetings by appointment.

**There are no set standards for exterior door pressures, but no more than 10 pounds is recommended. Interior doors have a required pressure of 5 pounds or less. Both interior and exterior door closure times cannot take less than 5 seconds to close.

**There must always be a 36” wide accessible pathway throughout the lobby area before being buzzed in. Each doorway must be at least 32” wide. The accessible parking spaces must be fully accessible to the lobby.

High Priority	Moderate Priority	Low Priority
<ul style="list-style-type: none"> » Exterior Main Door to Town Hall: <ul style="list-style-type: none"> » Push Pressure: 15 pounds » Pull Pressure: 11 pounds » Closure Time: 2.63 seconds » Interior Door that Requires Buzzer <ul style="list-style-type: none"> » Push Pressure: 11 pounds » Pull Pressure: 10 pounds » Closure Time: 3.69 seconds 	<ul style="list-style-type: none"> » Help desks and/or service counters should generally be no more than 36” high. » The lobby should be large enough to accommodate a wheelchair resting space (generally 36” wide by 48” long). 	<ul style="list-style-type: none"> » n/a

Technically Infeasible or Not Applicable
(due to changing standards or measurements within tolerance range)

» n/a

Currently, there are no High, Moderate or Low Recommendations

Council Chambers

Note: **There are no set standards for exterior door pressures, but no more than 10 pounds is recommended. Interior doors have a required pressure of 5 pounds or less. Both interior and exterior door closure times cannot take less than 5 seconds to close.

High Priority

- » Public bathroom is not accessible due to steps and narrow doorways.
 - » Most doorways are 30" wide. Doorways must be at least 32" wide.
- » Exterior Left Door (Left from inside the building)
 - » Push Pressure: 9 pounds
 - » Pull Pressure: 8 pounds
 - » Closure Time: 3.32 seconds (high)
- » Exterior Right Door (Right from inside the building) (high)
 - » Push Pressure: 20 pounds
 - » Pull Pressure: 15 pounds
 - » Closure Time: 1.85 seconds

Moderate Priority

- » Wheelchair resting areas must be provided within council chambers.
 - » 1 wheelchair space per every 25 seats
 - » Spaces generally must measure 36" wide by 48" long

Low Priority

» n/a



Public bathroom is not accessible due to steps and narrow doorways



Wheelchair resting areas must be provided within council chambers.

Technically Infeasible or Not Applicable
(due to changing standards or measurements within tolerance range)

» n/a

Currently, there are no High, Moderate or Low Recommendations

Restroom

High Priority	Moderate Priority	Low Priority
<p>» There is no accessible way to access the restroom. Most doorways have steps and are too narrow. Doorways must be at least 32" wide with a 36" wide accessible path leading to public elements.</p>	<p>» Currently, accessible restroom signage is located on the restroom door. Accessible restroom signage should always be placed on the latch side of the doorway. Please refer to Priority 3 – Toilet Rooms for restroom signage placement and contrast standards (moderate)</p> <p>» Appendix A</p> <p>» There must be a clear path to at least one of each type of fixture (e.g. sink, hand dryer, etc.) that is at least 36" wide. Currently, there is not 36" of maneuverable space between the toilet and the cabinet. (moderate)</p> <p>» Clearance around the toilet must measure 60" from the side wall and at least 56" from the rear wall. The restroom fits these dimensions, however, the cabinet leaves only 29" of maneuverable area in front of toilet. *If constructed before 3/15/12, clearances are more lenient. (generally 48" wide by 66" long or 48" wide by 56" long depending on the approach)</p>	<p>» n/a</p> <p>Technically Infeasible or Not Applicable (due to changing standards or measurements within tolerance range)</p> <p>» Coat hooks are not required, however, if present, can be no less than 15" and no greater than 48" above the floor. The current coat hook is 70" high.</p>

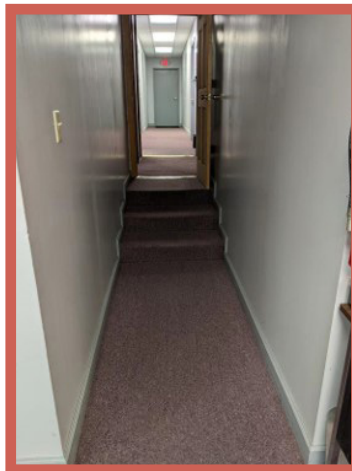

There is no accessible way to access the restroom



Accessible restroom signage should be placed on the latch side of the doorway.

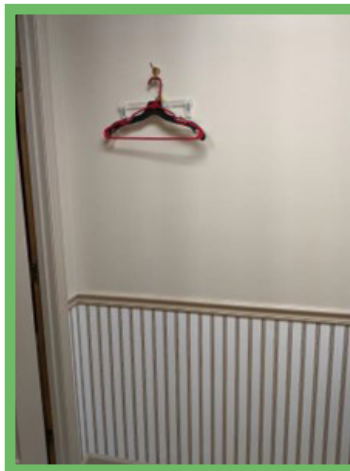

Lower coat hanger.

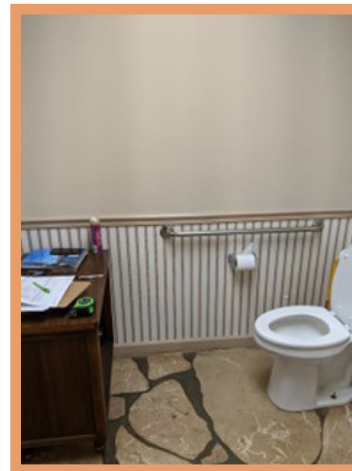

Currently not enough maneuverable space.

Restroom Cont.

High Priority	Moderate Priority	Low Priority
» n/a	<ul style="list-style-type: none"> » When a mirror is mounted above a sink, the bottom edge of the reflecting surface must be no higher than 40". Currently, the bottom edge of the reflecting surface is 52" above the floor. » Pipes below the sink must be fully insulated or configured to protect against contact. Currently, the pipes below the sink are only partially insulated. » Side grab bars above toilets must be at least 42" long on the side wall. It must be located no more than 12" from the rear wall and extend at least 54" from the rear wall. The grab bar must be mounted between 33" and 36" above the floor. The current side grab bar is only 36" long. » The rear grab bar must be at least 36" long on the rear wall. The current rear grab bar is only 18' long. 	<ul style="list-style-type: none"> » The soap dispenser mounted on the wall next to the sink is not currently utilized. If utilized, the dispenser should be moved no higher than 48" above the floor. The current dispenser is 51" above the floor. » The towel dispenser is currently 48" above the floor and mounted over the sink. When over sinks or counters less than 20" and no greater than 25" deep, towel dispensers must not be 44" above the floor.



Lower mirror.

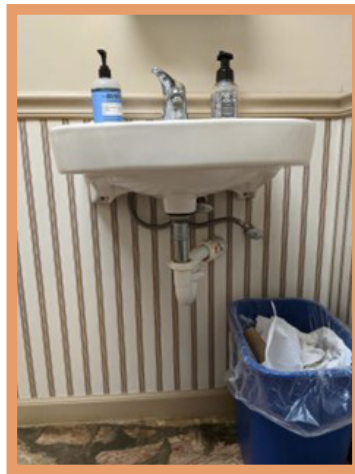

Fully insulate pipes.



Side bar grab needs to meet designated requirements.

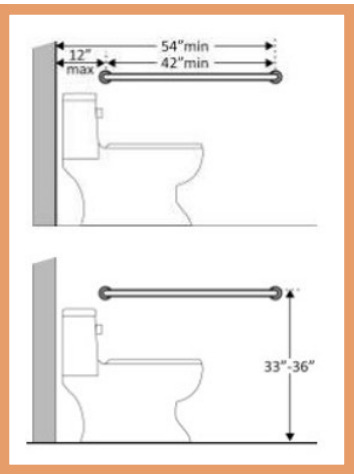

Restroom Cont.

High Priority	Moderate Priority	Low Priority
» n/a	» ADA requires flush handles on the open side of the toilet. The current flush handle is next to the wall.	» n/a

Technically Infeasible or Not Applicable (due to changing standards or measurements within tolerance range)

» The toilet paper dispenser must be located no less than 7" and no greater than 9" from the front of the toilet to the center of the dispenser. **If constructed before 3/15/12 dispenser does not need to be relocated if it is within reach from the toilet.

Currently, there are no High, Moderate or Low Recommendations



Rear grab bar should meet designated requirements.

Water Fountain

High Priority	Moderate Priority	Low Priority
» n/a	» n/a	» The water fountain does not currently meet the 2010 ADA Standards for Accessible Design. Please follow Priority 4 - Additional Access in the Appendix when making changes to lower priority structures such as water fountains. (Appendix A)
Technically Infeasible or Not Applicable (due to changing standards or measurements within tolerance range)		Currently, there are no High, Moderate or Low Recommendations
» n/a		



Fountain does not meet current design standards.

General

Note: **Ramps and wider doorways are necessary at all steps to make public spaces accessible. Please see Appendix "Approach and Entry" for ramp standards.

High Priority	Moderate Priority	Low Priority
» Directional signage at stairs is necessary to show alternative routes that are accessible. This is not a fix to not having accessible routes to all areas open to the public. This is temporary until wider doorways, ramps and/or other more permanent fixes are in place.	» n/a	» n/a
High Priority Recommendation	Technically Infeasible or Not Applicable (due to changing standards or measurements within tolerance range)	Currently, there are no Moderate or Low Recommendations
» High visibility reflective tape is recommended on all stairs.	» n/a	



Examples of recommended signage

Public Works

Parking and Entrance

High Priority	Moderate Priority	Low Priority
<ul style="list-style-type: none">» Currently there is no designated accessible parking» The entrance must be flush with the doorway to allow access for all users	» n/a	» n/a
Technically Infeasible or Not Applicable (due to changing standards or measurements within tolerance range)		Currently, there are no High, Moderate or Low Recommendations
» n/a		



Entrance should be flush

Men's Restroom

High Priority	Moderate Priority	Low Priority
<ul style="list-style-type: none"> » Compartment around toilet only 28" wide – ADA Standards require an open side of the toilet where the flush handle is located. Toilet compartments must measure 60" wide and 56" deep. There is currently not enough clearance around the toilet. <ul style="list-style-type: none"> » There must also be at least 48" for a forward approach to the sink. There is currently only 45" between the toilet and the sink. 	<ul style="list-style-type: none"> » Signage for the restroom should be in Braille and mounted on the latch side of the door at the heights designated in Appendix A Priority 3 – Toilet Rooms » There is not sufficient knee space for the sink – ADA Standards require at least 27" clearance from the floor to the bottom of the sink that extends at least 8" under the sink for knee clearance. 	<ul style="list-style-type: none"> » 48" tall soap dispenser over utility sink – If above a sink or countertop between 20-25" deep, the soap dispenser cannot be higher than 44" above the floor. <ul style="list-style-type: none"> » A soap dispenser can only be mounted 48" high when the sink/counter is less than 20" deep.
<p>Technically Infeasible or Not Applicable (due to changing standards or measurements within tolerance range)</p>		<p>Currently, there are no High, Moderate or Low Recommendations</p>
<p>» n/a</p>		

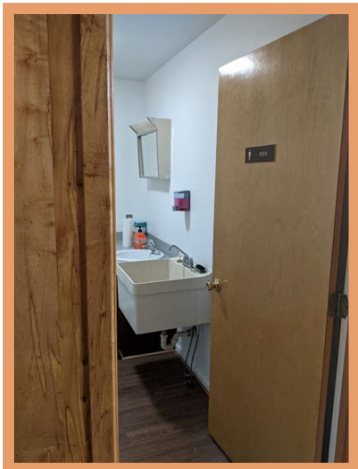

Signage should be in braille and mounted on latch side of door



There is currently not enough clearance around the toilet

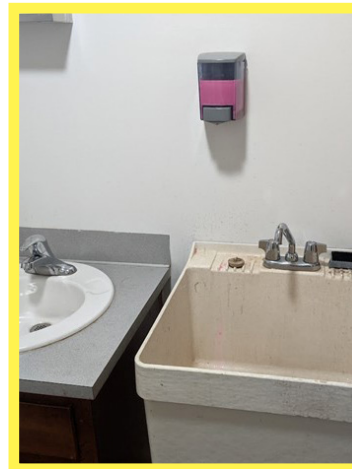

Soap dispenser should be mounted 48" high max when sink/counter is less than 20" deep



Not enough knee space under the sink

Women's Restroom

High Priority	Moderate Priority	Low Priority
<ul style="list-style-type: none"> » Compartment around toilet only 32.5" wide – ADA Standards require an open side of the toilet where the flush handle is located. Toilet compartments must measure 60" wide and 56" deep. There is currently not enough clearance around the toilet. <ul style="list-style-type: none"> » There must also be at least 48" for a forward approach to the sink. There is currently only 41" between the toilet and the sink. 	<ul style="list-style-type: none"> » There is not sufficient knee space for the sink - ADA Standards require at least 27" clearance from the floor to the bottom of the sink that extends at least 8" under the sink for knee clearance. » Signage for the restroom should be in Braille and mounted on the latch side of the door at the heights designated in Appendix A Priority 3 – Toilet Rooms 	<ul style="list-style-type: none"> » n/a
<p>Technically Infeasible or Not Applicable (due to changing standards or measurements within tolerance range)</p>		<p>Currently, there are no High, Moderate or Low Recommendations</p>
<ul style="list-style-type: none"> » n/a 		

General

- » The countertop is 40" tall. ADA Standards require that service counters include a portion of counter space that is no higher than 36" high and 36" long.
 - » This should not be an issue since guests can also utilize one of the desks within the building.

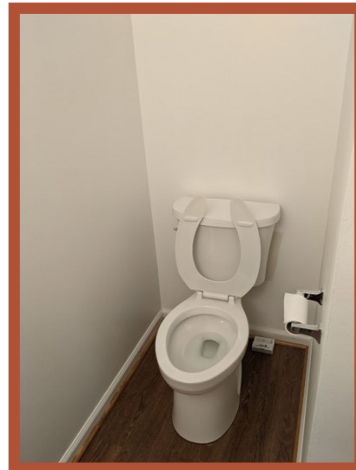

There is currently not enough clearance around the toilet

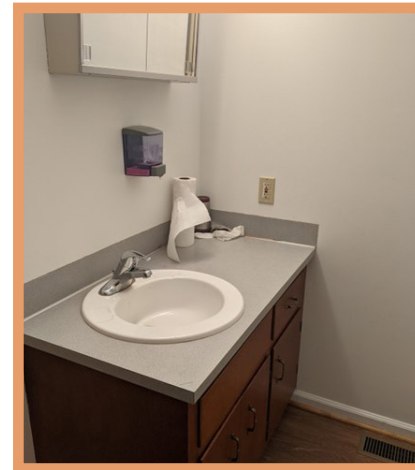

There is not enough knee space under the sink

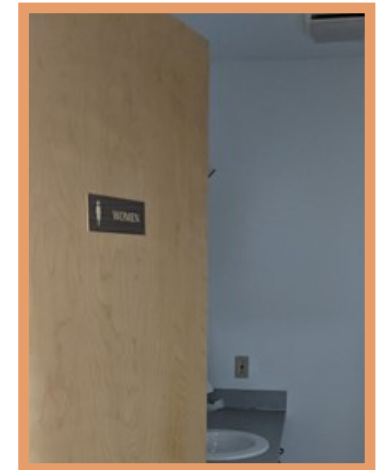

Signage should be in braille and mounted on latch side of door

Page intentionally left blank

Parks

The ADA National Network guidelines for play areas can be found in Appendix B. This checklist was used by the project team while inventorying play areas. While a checklist is provided to ensure compliance, items are not prioritized in the same manner as the previous facilities. Priorities and scoring systems are not provided by the standards found in Appendix B. In discussions with ADA Specialists, items within parks and play areas should be addressed with the following points as guidance:

- Safety and accessibility are the most important items to consider in play areas.
- Focus less on the ratio of elevated components to ground components and focus more on accessible yet safe surface material and accessible pathways to play components.
- Some materials, though accessible, can be unsafe and can cause liability concerns (for example, concrete surfaces at elevated play components could be a safety hazard). This is known as “Impact Attenuation of Surfacing Materials Within the Use Zone of Playground Equipment”.
- Accessibility is just as important for a disabled parent/grandparent/caregiver of a child visiting the playground as it is for a child with a disability. Therefore, accessible pathways are very important to play areas regardless of the type of play element.
- Making play areas compliant can be very expensive. ADA Specialists recommend prioritizing one entire playground at a time as opposed to making small improvements to several playgrounds.
- Sources to approved accessible sources can be found in Appendix C.

Items to note within the play area checklist:

- An elevated play component is defined as a component approached above or below grade that is part of a structure of two or more play components providing more than one play activity. Play components that are attached to a composite play structure and that can be approached from a platform or deck area are considered elevated play components.
- Ground level play components are components that can be approached and exited at ground level. For example, a child approaches a spring rider at ground level via the accessible route. The child may ride then exit directly back onto the accessible route. The activity is considered ground level because the child approaches and exits it from the ground-level route.

- Play components can be stand alone or part of a composite play structure. Different types of play components are based on the general experience provided by the play component. Different types include, but are not limited to, experiences such as rocking, swinging, climbing, spinning, and sliding. The number of steps/ladders does not come into play when inventorying the number of play elements. What is looked at is the number of different types of play experiences on the composite play structure.
- It is best practice to have at least one of each ground level play component on an accessible route.
- An accessible route is at least 36" wide and is stable, firm, and slip-resistant. The compliant surface must extend to the play element for safe access for all users.

If there are elevated play components:

- To make things equal for persons unable to access elevated play components, ADA Standards use the following chart to determine the number of additional ground play components required to be on an accessible route. The chart uses a ratio of elevated play components to ground components. If more than one ground play element is deemed necessary by the chart, the ground play elements must offer different play experiences and must be dispersed throughout the play area on an accessible route.
- To simplify, there are two requirements addressing how many ground-level play components must be on an accessible route. One of each type of ground level play components must be accessible and the ground-level requirements based on the number of elevated play components according to the chart. For example, if a play area has swings and rockers ground level and one elevated play component, there must be one rocker and one swing on an accessible route as they offer different play experiences. The chart will then determine if any additional ground play components must be accessible.

Number of Elevated Play Components Provided	Minimum Number of Ground Level Play Components Required to be on an Accessible Route	Minimum Number of Different Types of Ground Level Play Components Required to be on an Accessible Route
1	n/a	n/a
2 to 4	1	1
5 to 7	2	2
8 to 10	3	3
11 to 13	4	3
14 to 16	5	3
17 to 19	6	3
20 to 22	7	4
23 to 25	8	4
26 and over	8, plus 1 for each additional 3, or fraction thereof, over 25	5

‡ Park items are not prioritized in the same manner as the previous facilities. Prioritize one entire play area at a time as opposed to making small improvements to several play areas.

Veteran's Park

Note: **There are no set standards for exterior door pressures, but no more than 10 pounds is recommended. Interior doors have a required pressure of 5 pounds or less. Both interior and exterior door closure times cannot take less than 5 seconds to close.

Women's Restroom

Door Pressures for Exterior Door and faucet pressure:

- » Push Pressure: 7 pounds
- » Pull Pressure: 9 pounds
- » Closure Time: 3.60 seconds
- » The water requires 9 pounds of pressure to operate the faucet. ADA restricts push pressures to 5 pounds of pressure or less for faucets.

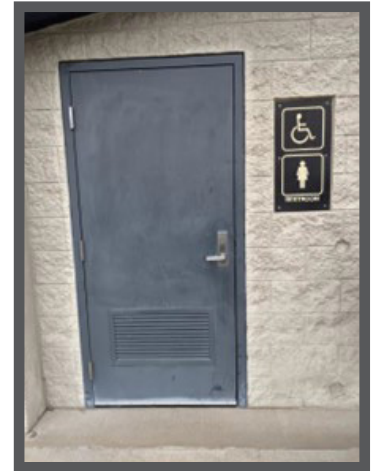

Men's Restroom

Door Pressures for Exterior Door and faucet pressure:

- » Push Pressure: 8 pounds
- » Pull Pressure: 9 pounds
- » Closure Time: 2.81 seconds
- » Keep all faucet pressures at sinks at 5 pounds or pressure or less for operation.

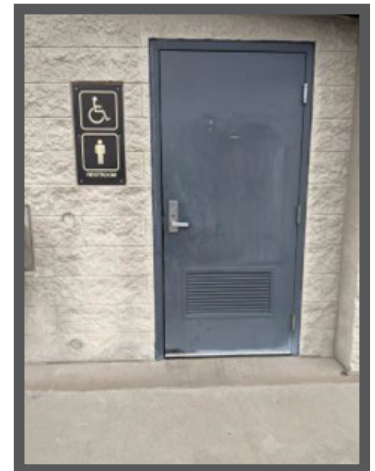

Parking Area

Note: **The running slope and cross slope of each accessible space and accessible aisle is measured at the top (area closest to the concrete parking block), middle, and bottom. According to ADA Standards, the slope of accessible parking spaces and access aisles should be no greater than 2% in all directions.

- » All accessible and van accessible spaces (at both fields) are within proper running and cross slope measurements. All spaces are signed appropriately and have the necessary width for both accessible spaces and access aisles.
- » The driveway cut at the restrooms has a cross slope of 5.8%. Driveway cuts must maintain a cross slope of 2% or less.

- » Driveway cuts that cross pedestrian routes must have a 2% or less cross slope.
- » The curb ramps at the accessible spaces (closest to the restrooms) have no level landing and creates a 5% cross slope for pedestrians using the sidewalk. Example curb ramp types are shown below. The first example shows a top landing that prevents pedestrian hazards when crossed. The second example shows parallel curb ramps used for confined spaces. The limited slope and flat landing prevents pedestrian hazards.

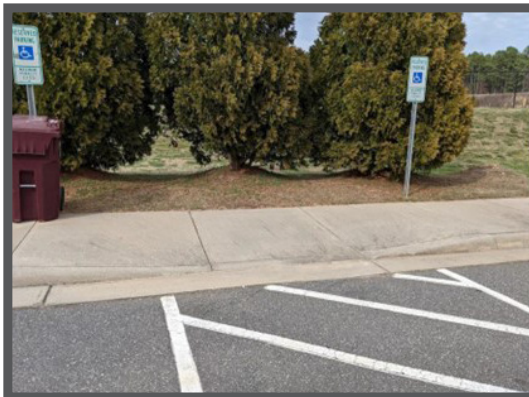
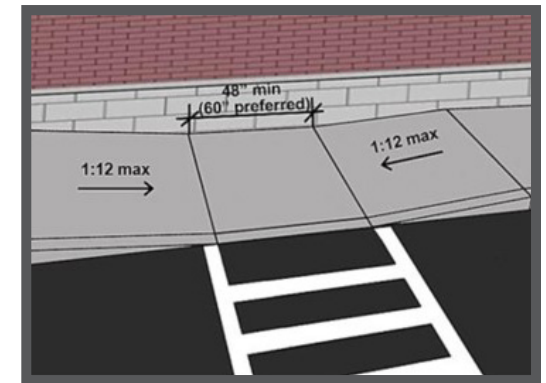
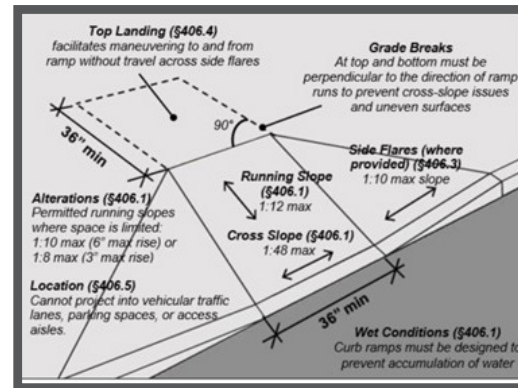
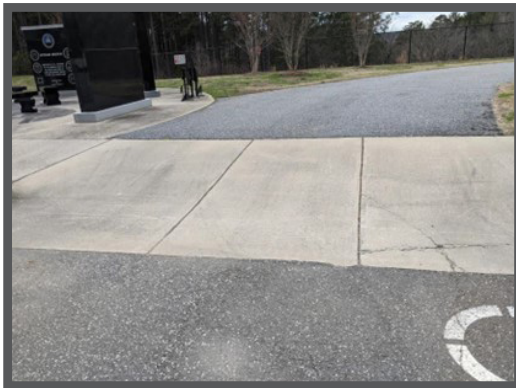
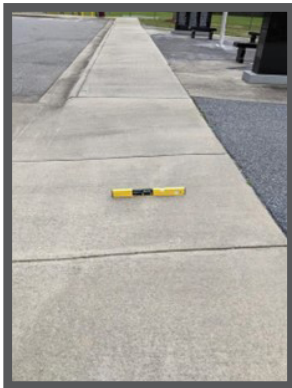

The curb ramp closest to the soccer field has a top landing right next to the stairs. Recommend high-viz striped tape on the stairs as well as directional signage showing the nearest accessible route. (high recommendation)

Field 1

- » Field one is not accessible to all users. An accessible path should lead from the parking area to the bleachers with a paved (or other accessible material), level resting area (next to the bleachers) for persons in wheelchairs. Wheelchair spaces cannot overlap circulation paths. The path should also extend to team and player seating. Currently, the path to the bleachers and team seating at field 1 is gravel and not accessible to all users. The fields, however, can remain a grass surface. Please see the sources below for possible accessible path materials.
- » Please see Appendix C.1 for some of the stipulations on ADA playground and accessible route surfaces.
- » Please see Appendix C.2 for multiple ground surfaces to consider in both play grounds and accessible paths.
- » Please see Appendix C.3 for potential ADA compliant surfaces for trails.



Field 2

- » An accessible path should lead from the parking area to the bleachers with a paved, level resting area (next to the bleachers) for persons in wheelchairs. Wheelchair spaces cannot overlap circulation paths. The path should also extend to team and player seating. Recommend extending the pavement (or other accessible material) to connect to the cement pad at the bleachers and player seating.
- » Currently, there is a fenced off gravel path.
- » Please see links under Field 1 for possible accessible path materials.



Lower Veteran's Park

- » The curb ramps at the accessible parking spaces do not follow ADA measurements. The current curb ramps create an unsafe cross slope for all pedestrians. Please see the example below of a parallel curb ramp. The parallel curb ramp is the best fit for the space.

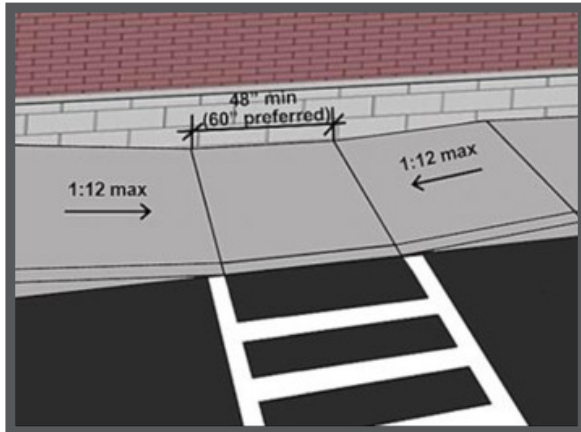

Parking at Lower Veteran's Park

The 6th accessible space (far right) is not signed. Accessible signage must be posted 60" from the ground to the bottom of the sign.



Note: **The running slope and cross slope of each accessible space and accessible aisle is measured at the top (area closest to the concrete parking block), middle, and bottom. According to ADA Standards, the slope of accessible parking spaces and access aisles should be no greater than 2% in all directions.

All spaces were within proper slope and space dimensions.

Women's Restroom - Lower Veteran's Park

Note: ** There are no set standards for exterior door pressures, but no more than 10 pounds is recommended. Interior doors have a required pressure of 5 pounds or less. Both interior and exterior door closure times cannot take less than 5 seconds to close.

- » Door Pressures (exterior door leading into facility):
 - » Push Pressure: 13 pounds
 - » Pull Pressure: 15 pounds
 - » Closure Time: 2.91 seconds
- » Pipes aren't insulated below the sink. According to ADA, all pipes must be insulated beneath sinks.
- » When located over sinks, the operable portion of soap dispensers can be no higher than 44". Currently, the soap dispenser is over the sink and 52" high.
- » Coat hooks must be higher than 15 inches and no greater than 48 inches above the floor. Currently, the hook is 52" high.
- » According to ADA, stall doors must be self-closing. Currently, the stall does not self-close.

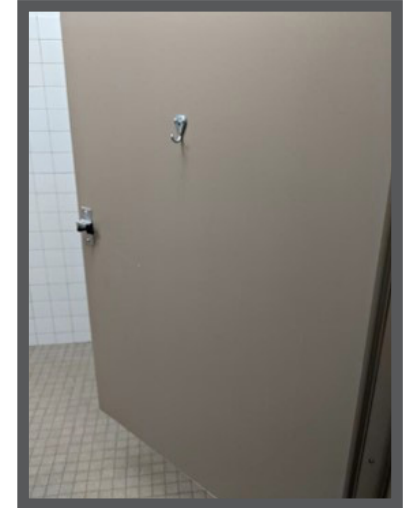
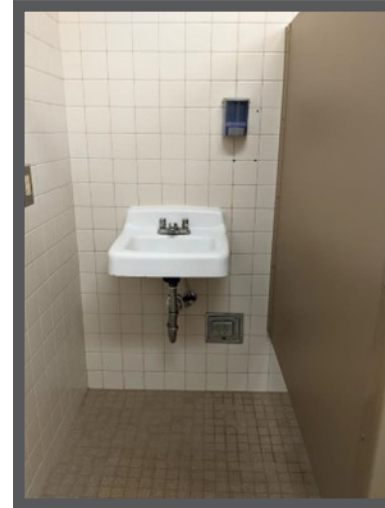

Men's Restroom - Lower Veteran's Park

Note: **There are no set standards for exterior door pressures, but no more than 10 pounds is recommended. Interior doors have a required pressure of 5 pounds or less. Both interior and exterior door closure times cannot take less than 5 seconds to close.

- » Door Pressures (exterior door leading into facility):
 - » Push Pressure: 12 pounds
 - » Pull Pressure: 12 pounds
 - » Closure Time: 4.19 seconds
- » Pipes aren't insulated below the sink. According to ADA, all pipes must be insulated beneath sinks.
- » When located over sinks, the operable portion of soap dispensers can be no higher than 44". Currently, the soap dispenser is over the sink and 49" high.

- » Coat hooks must be higher than 15 inches and no greater than 48 inches above the floor. Currently, the hook is 52" high.
- » According to ADA, stall doors must be self-closing. Currently, the stall does not self-close.

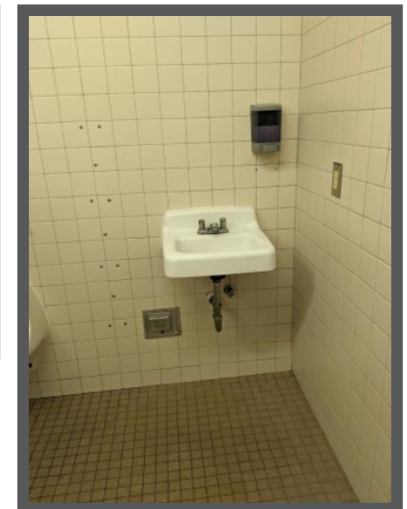

Playground

- » The current gravel surface in the playground is not ADA compliant.
 - » Appendix C.1 covers some of the stipulations for ADA playground and accessible route surfaces.
 - » Appendix C.2 covers multiple ground surfaces to consider in both play grounds and accessible paths.
 - » There must be an ADA accessible route to one of each park element. One bench, gazebo, seesaw, slide, bouncer, and swing must connect to the entry/exit of the park. The entry and exit of the park must also connect to the parking area via accessible route. This is the only way persons in wheelchairs (guardians or children) can safely access these elements.

- » Recommendation: There are currently no ADA Standards regulating disc golf. It is, however, recommended that a small portion of holes are accessible to all by means of accessible routes. Accessible routes are continuous, unobstructed paths connecting all accessible elements.
- » Recommendation: Accessible playground equipment is recommended for this park. Currently, there is no inclusive playground equipment.

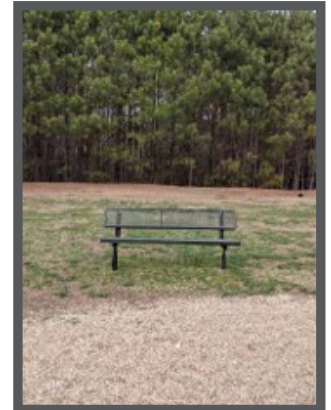
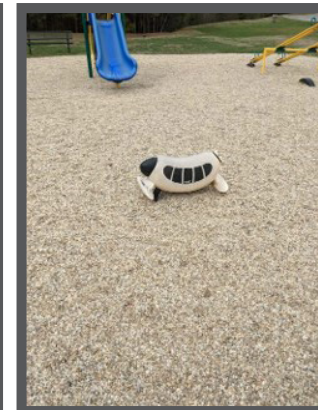
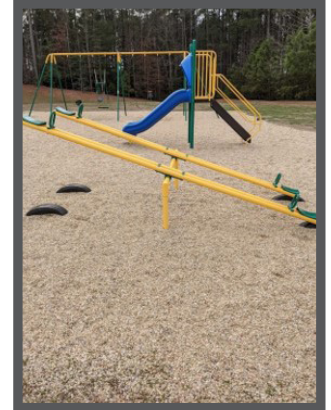
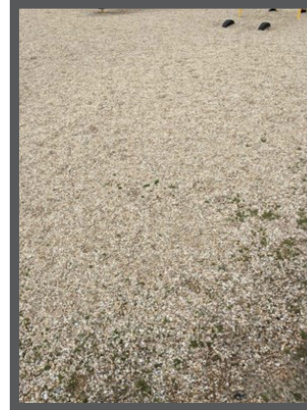

Baird Park

Play Area & Park

- » The running slope along the sidewalk connecting the road to the park is 14%. When not following a roadway, running slope must be 5% or less.
- » A smoother transition is needed from the parking lot to the asphalt path. Vertical discontinuities cannot exceed 1/2".
- » There is currently a steep dip due to a ditch at the entrance to the park (that leads up to the restrooms). This dip causes a sudden running slope of 10.5% and could be hazardous to those with ambulatory disabilities.
- » Gravel is not an ADA accessible surface. While one of the composite play structures includes an ADA accessible ramp, there should also be accessible exits (i.e. at the bottom of slides and other exit points). One of each play element must be connected by an accessible path to the entrance/exit points of the play area OR the entire surface of the play area must be replaced with an ADA approved surface. Loose material like gravel will not perform adequately unless it is sufficiently stabilized by binders, compaction, or other treatments and will likely require repeated maintenance.
- » An ADA accessible path is necessary to connect the entry and exit points of one composite play structure (i.e. the slides), the drums, zipline, rock wall, one swing, the spinner, and seesaw. This accessible path must also connect to the park entrance/exit.



Play Area & Park (cont.)

- » An ADA accessible path must connect one picnic shelter to the existing accessible path at the parking lot. The shelter must also be fully accessible.
- » The ADA accessible path must also connect to accessory structures. This includes one trash can, pet waste station, and one bench. It is recommended that one (or more) bench(es) have a paved resting area next to the bench large enough for a wheelchair resting area.
- » Include an accessible path to the batting cage, bleachers at each ball field, and the ball fields. The accessible pathway can be composed of many different surface types. Please see Appendix C.1 or C.3 for more information.
- » Each set of bleachers should have an accessible area for wheelchairs. There should generally be one space for every 25 seats. The space should measure 36"x48" deep for forward approach and 36"x60" for parallel approach. A clear, accessible path to the wheelchair spaces should be 36" wide.
- » Add directional signage at staircases noting where accessible pathways can be found.
- » There is a vertical discontinuity that could be a trip hazard at the top of the staircase. The asphalt should be beveled to correct.

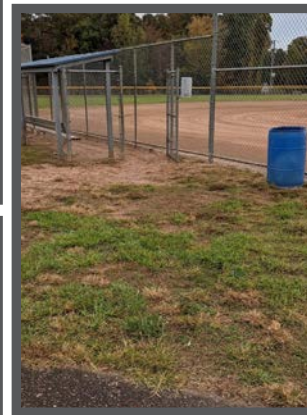
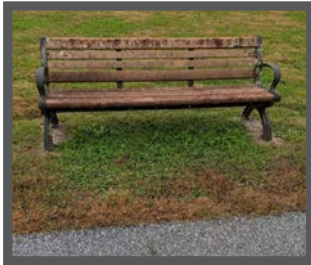

- » Recommendation: Include yellow reflective tape on steep staircases.

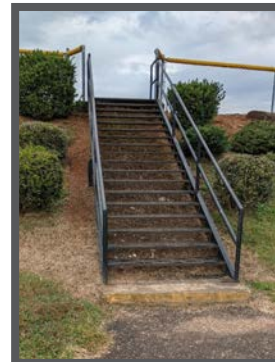
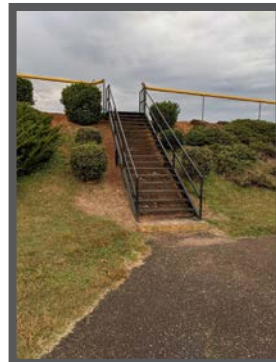

Women's Restroom

- » The operable parts of the light switch can be no higher than 48" above the floor. Currently, the light switch is mounted 50" above the floor. *If constructed before 3/15/2012 and a parallel approach is provided, controls can be 54" above the floor.*
- » ADA Standards require restroom signs to contrast with their background. The current sign is placed correctly, however, is faded and cannot be seen by all users.
- » The bathroom door is currently very difficult to push open. Generally, ADA Standards require 5 pounds of maximum force for opening doors. There are, however, no standards for exterior doors. The maximum amount of recommended force is 10 pounds with a 5 second closure time.
- » The sink can be difficult to turn on. The force required to activate the faucet can be no greater than 5 pounds.
- » Currently, the back of the toilet reaches the rear grab bar. There must be at least 1.5" clearance between the grab bar and objects below. *If constructed before 3/15/2012, grab bars do not need to be relocated. There are no space requirements above and below grab bars in the 1991 standards.*
- » The toilet paper dispenser must be located no less than 7" and no greater than 9" from the front of the toilet to the centerline of the dispenser. Currently, the toilet paper dispenser is 15" from the front of the toilet to the centerline of the dispenser.
- » The stall door is not self-closing as required by ADA standards.
- » The stall door only has a handle on one side. *If constructed before 3/15/2012, door pulls are not required.
- » If a mirror is installed above the sink, the bottom edge of the reflecting surface must be no higher than 40" above the floor.
- » If located above the sink, the operable part of the soap dispenser can be mounted no higher than 44" above the floor. The current soap dispenser is 48" high.
- » Shift the trash can to make a 36" wide accessible pathway to the sink and the hand dryer. Currently, both are obstructed due to the trash can location.

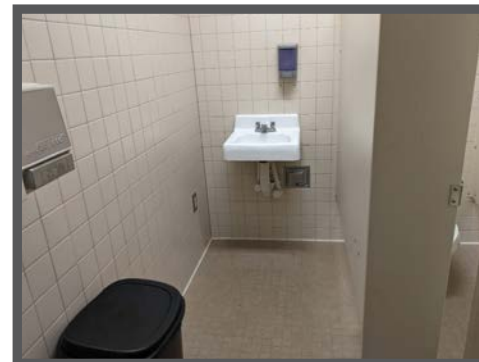
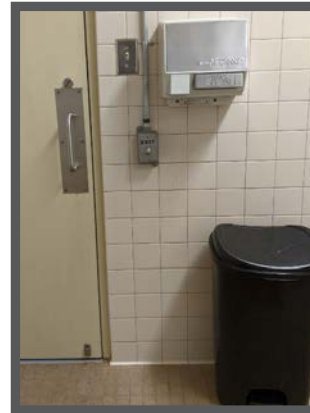

Men's Restroom

- » The operable parts of the light switch can be no higher than 48" above the floor. Currently, the light switch is mounted 50" above the floor. *If constructed before 3/15/2012 and a parallel approach is provided, controls can be 54" above the floor.*
- » ADA Standards require restroom signs to contrast with their background. The current sign is placed correctly, however, is faded and cannot be seen by all users.
- » The stall door is not self-closing as required by ADA standards.
- » The stall door only has a handle on one side. *If constructed before 3/15/2012, door pulls are not required.
- » Currently, the back of the toilet reaches the rear grab bar. There must be at least 1.5" clearance between the grab bar and objects below. *If constructed before 3/15/2012, grab bars do not need to be relocated. There are no space requirements above and below grab bars in the 1991 standards.*
- » The toilet paper dispenser must be located no less than 7" and no greater than 9" from the front of the toilet to the centerline of the dispenser. Currently, the toilet paper dispenser is 16" from the front of the toilet to the centerline of the dispenser.
- » If located above the sink, the operable part of the soap dispenser can be mounted no higher than 44" above the floor. The current soap dispenser is 48" high.
- » The bathroom door is currently very difficult to push open. Generally, ADA Standards require 5 pounds of maximum force for opening doors. There are, however, no standards for exterior doors. The maximum amount of recommended force is 10 pounds with a 5 second closure time.
- » The sink can be difficult to turn on. The force required to activate the faucet can be no greater than 5 pounds.

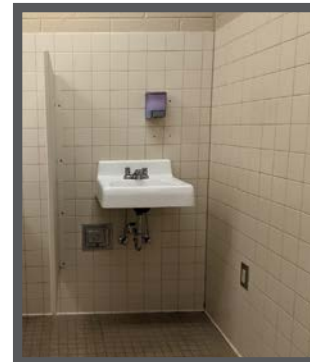

Parking Area

- » **The running slope and cross slope of each accessible space and accessible aisle is measured at the top (area closest to the concrete parking block), middle and bottom. According to ADA Standards, the slope of accessible parking spaces and access aisles should be no greater than 2% in all directions.
- » 6 accessible spaces
- » 2 of the above spaces are van accessible
- » All spaces are proper dimensions and signed appropriately
- » There are currently 173 spaces. One of every 25 spaces must be designated an accessible space. Currently, there are only 6 accessible spaces. There should be one more accessible space to be fully compliant.
- » Far Left Space (#1):
 - » Cross Slope Ranges: 2.8 - 3.4%
 - » Running Slope Ranges: 3.7 – 5.7%
 - » Measurement: 8 ft wide
- » Striped Access Aisle (#1):
 - » Cross Slope Ranges: 3.1 -3.9%
 - » Running Slope Ranges: 3.5 – 5.2%
 - » Measurement: 5 ft wide
- » Next Space from Left (#2):
 - » Cross Slope Ranges: 2.5 – 3%
 - » Running Slope Ranges: 3.4 – 4.9%
 - » Measurement: 9 ft wide
- » Shared Access Aisle (same measurements as above from Access Aisle #1)
- » Accessible Space #3:
 - » Cross Slope Ranges: 2.3 – 3.1%
 - » Running Slope: 3.4 – 5%
 - » Measurement: 9 ft wide
- » Striped Access Aisle #2:
 - » Cross Slope Ranges: 2.8 – 3.7%
 - » Running Slope Ranges: 3.8 – 4.3%
 - » Measurement: 5 ft wide
- » Accessible Space #4:
 - » Cross Slope Ranges: 3.4%
 - » Running Slope Ranges: 3.6 – 4.3%
 - » Measurement: 8 ft wide
- » Shared Access Aisle (same measurements as above from access aisle #2)
- » Accessible Van Space:
 - » Cross Slope Ranges: 3.1 – 3.5%
 - » Running Slope Ranges: 2.6 – 4.2%
 - » Measurement: 8ft wide
- » Access Aisle for Van Spaces:
 - » Cross Slope Ranges: 3.5 – 4.4%
 - » Running Slope Ranges: 3.6 – 5%
 - » Measurement: 8ft wide
- » Accessible Van Space #2:
 - » Cross Slope Ranges: 3 – 3.8%
 - » Running Slope Ranges: 3.3 – 6.9%
 - » Measurement: 8 ft wide
- » Shared access aisle for van accessible spaces



Page intentionally left blank

Pedestrian Right of Way Collector Application

To document mobility hazards within Sawmills pedestrian right of way, the study team published a pedestrian right-of-way collector application for documenting mobility hazards within municipalities. Because ADA covers a broad range of criteria, the application covers criteria for sidewalks, curb ramps, driveway cuts, intersections, railroad crossings, bus stops, crosswalks, and pedestrian islands.

This application uses the most updated set of proposed PROWAG technical ADA standards from the US Access Board and is meant to serve as an overall inventory for Sawmills Public Works Department. Using GPS and GIS software, the application is a living document that provides locations and descriptions of mobility hazards or items not complying with standards. All items that are corrected or infeasible can be documented in the application. Items from the application are used in this report.

Note: Age of streets and sidewalks were not noted in the pedestrian application. As this application is utilized, it is important to note the following:

Requirements vary depending on the age of a highway, road, street, or sidewalk and whether it was paved, repaved, resurfaced beyond maintenance, or otherwise altered.

Street, sidewalks, roads, and highways that were built before January 26, 1992, and have not since been altered are considered “pre-ADA”. There were no standards in place when these were built and do not have to become compliant unless altered.

“Alterations” to roadways and new construction must comply with current ADA Standards. A street or sidewalk is included in this category if it was constructed prior to January 26, 1992 and has since been altered. Alterations made after January 26, 1992 must also comply with the latest ADA Standards. An alteration is a change that affects usability. Resurfacing a roadway beyond general maintenance is an alteration, however, filling potholes would not be considered an alteration since it does not affect usability.

Pedestrian Right of Way Methodology

Since the application is for Department of Public Works use, the following explains the methodology and ranking system used within the application. Most pedestrian infrastructure images used in this document are considered Priority 1 issues.

Priority 1 (Red) High: This category includes anything considered an immediate safety hazard according to standards. Many high priority items in the application can be corrected or improved by adding detectable warnings. Curb ramps or crosswalks leading pedestrians into roadways without detectable warnings (or truncated dome mats) automatically rank high priority. Detectable warnings are visually contrasting, colored mats with raised domes. This serves to warn pedestrians that are about to enter roadways. Detectable warnings are not necessary at driveway cuts, however, if not present at roadways and crosswalks, could present a dangerous mobility hazard for the visually impaired. Location, lighting, speed limits, and traffic volumes are also factors in determining which items should be ranked high priority. In addition to lack of detectable warnings,

dangerous mobility examples include but are not limited to impassable sections of sidewalk due to obstruction or damage, narrow driveway cuts with improper flares, inaccessible pedestrian signals, cross slopes exceeding 10%, dangerous pedestrian crossings, etc.

Priority 2 (Orange) Moderate: This category includes less severe, but still hazardous safety issues according to standards. Location, lighting, speed limits, and traffic volumes are also factors in determining moderate priority issues. Mobility hazards in this category include but are not limited to vertical discontinuities resulting in potentially dangerous transitions, smaller obstructions that do not completely block accessible paths, cross slopes ranging from 5-10%, unsafe pedestrian crossings, etc.

Priority 3 (Green) Low: This category includes non-compliant issues that do not pose an immediate safety hazard according to standards. Location, lighting, speed limits, and traffic volumes are also factors in determining low priority issues. Mobility hazards in this category include but are not limited to small vertical discontinuities exceeding .5", small cracks in sidewalks that could exceed .5" wide, most cross slopes ranging from 2-5%, etc.

Curb Ramps - PROWAG ADA Standards



- » Detectable warnings, or truncated dome mats, are what warns visually impaired individuals that they are about to enter a roadway with vehicular traffic. These mats must visually contrast with the surrounding pavement and be placed at the back of the curb, right before the gutter. There are exceptions where back of curb is not always feasible, however, detectable warnings must be present when entering roadways. Detectable warnings must cover the entire depressed segment of curb and must be 24 inches wide. There should be a smooth surface around detectable warnings so that mats are more easily noticed. Detectable warnings are not necessary at residential driveway cuts. They are recommended at busy commercial driveway cuts.
- » The depressed curb must be at least 36 inches wide to allow for wheelchair accessibility.
- » If one curb ramp serves two adjoining crosswalks at two adjoining streets, there must be a space 48 inches wide and 48 inches deep that is outside of vehicle travel lanes and within the crosswalks. This space must be as level as possible. This is known as a diagonal curb ramp. While diagonal curb ramps are allowed, they are not recommended. New construction is advised against using diagonal curb ramps.
- » The cross slope of each curb ramp is measured parallel to the back of each detectable warning. The cross slope must not exceed 2% for a 4' area.
- » The running slope, or running grade, is measured perpendicular to the back of the detectable warning, where the ramp slopes downward towards the gutter. The running slope of curb ramps cannot exceed 8.33%.
- » The cross slope at the gutter, or foot, of the curb ramp cannot exceed 5%. The cross slope in this location is measured parallel to the front of each detectable warning.
- » If the curb ramp has flares that encroach on the pedestrian path of travel, the slope of each flare must measure 10% or less. This is measured parallel to the curb.
- » Curb ramps must have a level turning space that is 48 inches wide and 48 inches deep. Most turning spaces are at the top of the curb ramp. Turning spaces cannot exceed a 2% slope in all directions. If the turning space is constrained, the level turning space must be 48 inches wide by 60 inches deep. Turning spaces are considered constrained if taller curbs or other items block the area needed for proper foot space while turning in a wheelchair.
- » The transition between the ramp and walkway or street must be smooth and flush with the adjacent pavement or asphalt. There cannot be abrupt level changes or obstructions.
- » Curb ramps should have proper alignment. Curb ramps should align on either side of the intersection and/ or roadway and lead pedestrians in the proper direction. In some cases, due to drainage or other issues, this is not always feasible. These instances should be noted as plan items are addressed.



Note: There are many different types of curb ramps. Standards can differ slightly depending on curb ramp type. The following are general requirements for curb ramps using US Access Board technical standards.

Sidewalks- PROWAG ADA Standards

- » Sidewalks must be at least 4 feet wide for the pedestrian path of travel. 5 feet of width is recommended.
- » There cannot be vertical discontinuities exceeding ½ inches. Vertical discontinuities include cracks, height differences in concrete slabs, etc.
- » Walkway joints, grate openings, and cracks cannot exceed ½ inches wide. If grate openings exceed ½ inches wide, they should be turned perpendicular to the pedestrian path of travel.
- » Objects measuring 2.25-6.7 feet high cannot protrude more than 4 inches into the pedestrian path of travel.
- » Guardrails or barriers must be 2.25 feet maximum above the surface.
- » The pedestrian path of travel cannot exceed a 2% cross slope. The cross slope is measured perpendicular to the pedestrian path of travel.
- » If the sidewalk is NOT following a roadway, the running slope cannot exceed 5%. The running slope is measured parallel to the pedestrian path of travel. Sidewalks following roadways can have the same running grade as the roadway.
- » There must be a smooth travel surface with solid, compliant surface material such as concrete.
- » Sidewalks cannot be buckled or cracked. As stated above, cracks that do not exceed ½ inches in width are permissible.
- » Sidewalks should not have uneven or depressed segments. Depressed segments do not meet proper slope requirements and can cause drainage issues.
- » Sidewalks should not have overgrown vegetation. Any vegetation encroaching on the pedestrian path of travel should be removed. This includes trees or foliage protruding more than 4 inches into the pedestrian path of travel.
- » Sidewalks should not have noticeable drainage issues. Pooled water can create mobility barriers.
- » Trees incorporated into the sidewalk design should be covered by grates. As noted above, grate openings cannot exceed ½ inches in width. If wider than ½ inches, grate openings must be perpendicular to the pedestrian path of travel.
- » Sidewalks should have a designated furniture zone in areas with benches, trash bins, light poles, etc. The furniture zone should be placed on the same side of the sidewalk throughout the municipality for consistency.

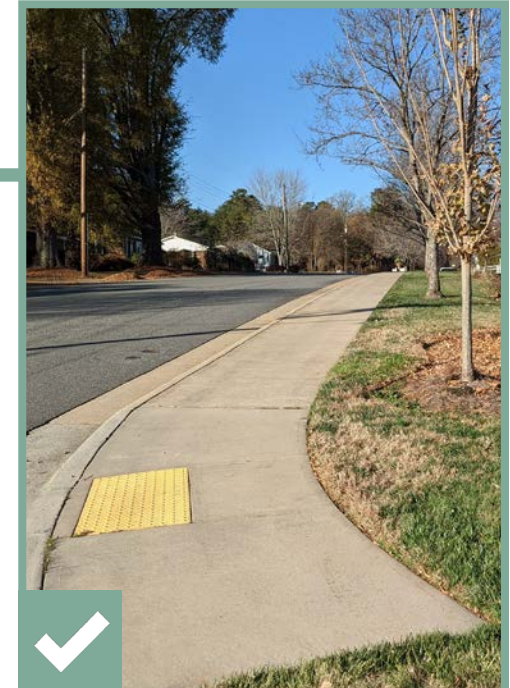
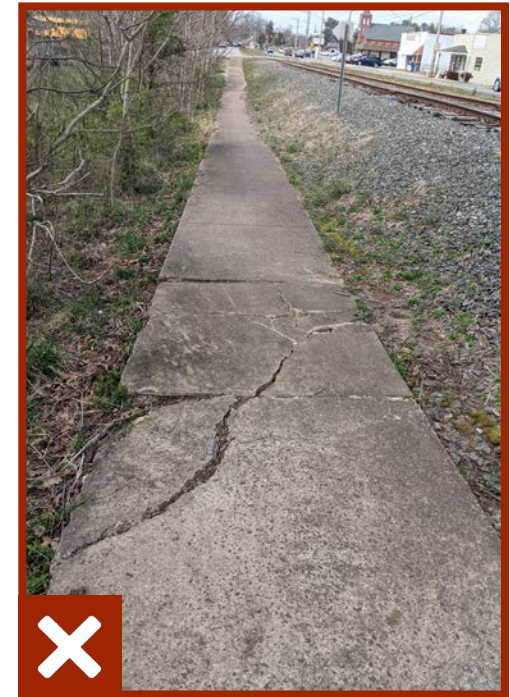

Pedestrian Islands

- » There must be at least 2 feet between detectable warnings.
- » Detectable warnings must be 24 inches in length at both openings. Detectable warnings are only required if the pedestrian island exceeds 6 feet in width.
- » The clear width of pedestrian access routes within medians and pedestrian refuge islands should be 5 foot minimum.
- » A slip lane is a traffic lane provided at an intersection to allow vehicles to turn at the intersection before merging and interfering with through traffic. The island must be raised at slip lanes except for at accessible openings.
- » Crosswalks must be one car length back at slip lanes as shown in the illustration.

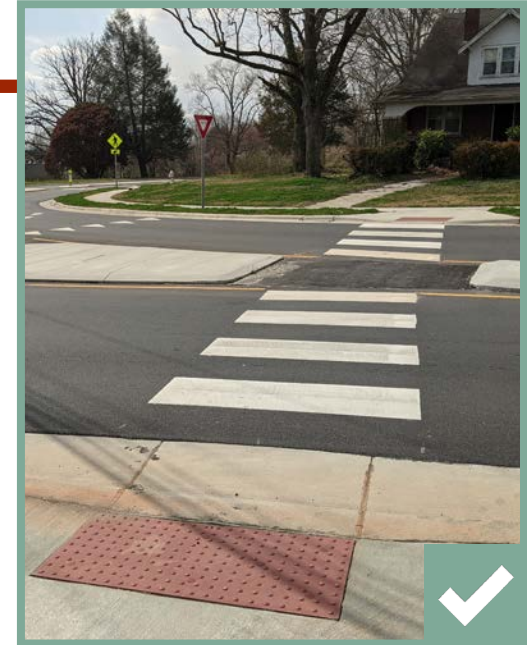
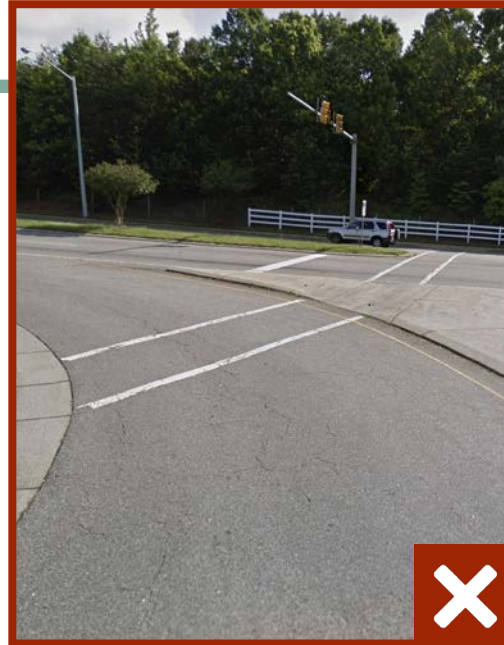

Railroad Crossings

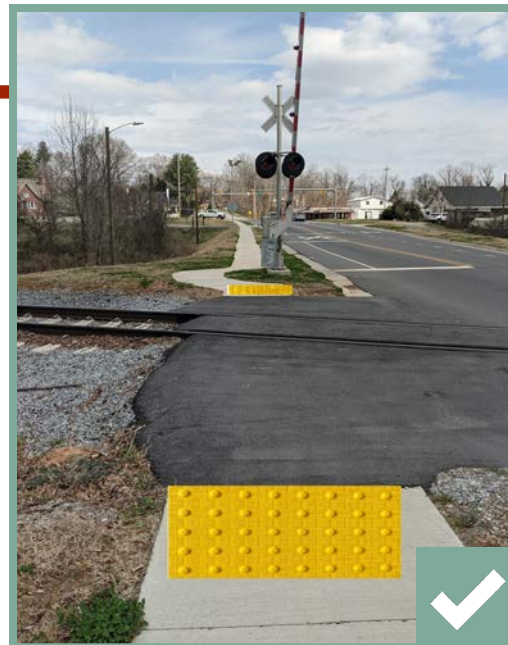
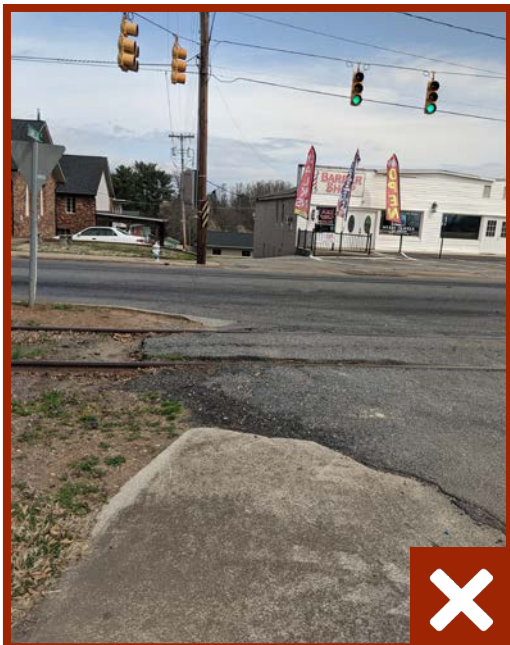

- » The pedestrian path must be at least 4 feet wide for the entire crossing. The surface between and on either side of the rails must be aligned with the top of the rails.
- » The flangeway gap can be a maximum of 2.5 inches. Flangeway gaps can be 3 inches wide on freight rail tracks.
- » A detectable warning (or truncated dome) must be located 6-15 feet from the centerline of the nearest rail. The detectable warning must extend the full width of the pedestrian crossing.

Pedestrian Signals

- » When facing the intersection, the push button for the crosswalk on your left should also be located to your left on the outside edge of the crosswalk, and the push button for the crosswalk on your right should be located to your right on the outside edge of the crosswalk. The push button face should also be aligned parallel with the direction of travel.
- » Some of the below standards only apply to new pedestrian signal installations. All signals, however, should be easily accessed by all users.
- » The push button should have a 4' X 4' landing with less than a 2% cross slope in all directions. The landing must be unobstructed and an all-weather surface. The landing can be 30" by 48" for a parallel approach.
- » The push button should be offset up to 5 feet maximum from the lateral projection of the outside edge of the cross walk.
- » The push button should be 1.5 feet to 10 feet from the back of curb. It is ideal to space it approximately 6 feet from the back of curb.
- » The push buttons should have at least 10 feet of separation between them. If located on a pork chop/island, the minimum separation between the push buttons should be at least 6 feet.
- » The face of the push button should be parallel to the crosswalk to be used.
- » The push button(s) shall be at a height of 15-48". The ideal height is 42".
- » The push button can have a 10 inch maximum horizontal reach. For example, a push button can be located up to 10" away from an accessible path/resting area.
- » There must be speakers at the pushbutton
- » There must be a tactile arrow showing pedestrians which direction the pedestrian signal serves. The MUTCD recommends that the tactile arrow vibrate.
- » A pushbutton locator tone is a repeating sound that informs approaching pedestrians that a pushbutton to actuate pedestrian timing or receive additional information exists, and that enables pedestrians with visual disabilities to locate the pushbutton. Standards indicate that alerts should be set to one tone per second.
- » The visual signal head should be mounted 7-10 feet high.

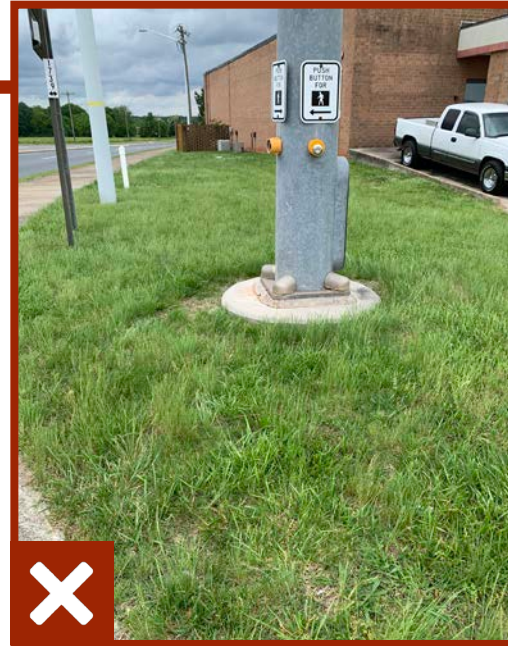

Crosswalks



- » Crosswalks must be 6-10 feet wide.
- » There must be a running grade of less than 5%. This is measured perpendicular to the curb.
- » The cross slope must be less than 2% if the crosswalk requires a stop or yield. This is measured parallel to the curb.
- » The cross slope must be less than 5% if the crosswalk is signalized or uncontrolled on approach. As stated above, the cross slope of crosswalks is measured parallel to the curb.
- » Mid-block crossings require equal street grade.
- » Markings are not required, however, recommended in areas with high traffic volumes. NCDOT requests that markings are present at intersections with pedestrian signals. As stated above, markings must be 6-10 feet wide if present. Crosswalks are present at stop signs and intersections regardless of markings.
- » Textured surfaces are not recommended. Smooth surfaces such as asphalt or concrete without patterns are recommended.
- » High visibility crosswalks are recommended at midblock crosswalks. This includes proper signage, rectangular rapid flashing beacon if applicable, high visibility markings, and overhead lighting.

Driveway Cuts

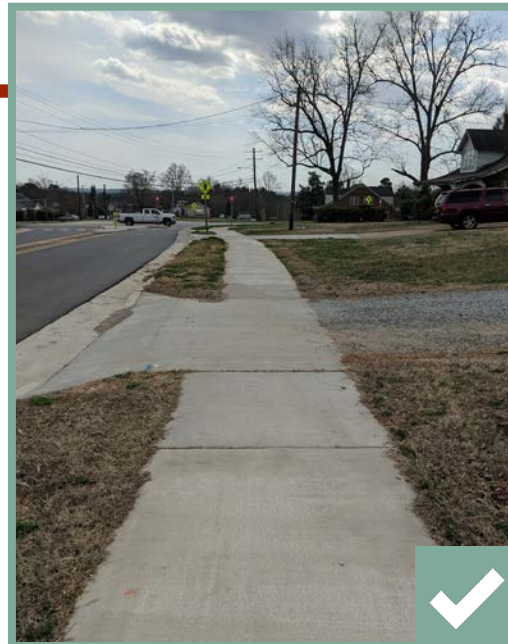

- » Driveway cuts must maintain a 4 foot wide, level pedestrian path of travel surface for the entire driveway cut.
- » Driveway cuts cannot exceed a 2% cross slope. The cross slope is measured perpendicular to the pedestrian path of travel.
- » Driveway cuts cannot have a rapid grade change at the flare. Flares at the beginning and end of each driveway cut should be out of the 4 foot wide pedestrian path of travel.

Introduction to Collector Application Categories and Technical Standards

The following images represent examples from each category covered within the pedestrian right of way collector application. This does not represent all items within the application. Images in green boxes represent pedestrian elements within Town of Sawmills that comply with ADA Standards. These images show how each pedestrian element should look within Town of Sawmills. Images in red boxes represent pedestrian elements within Sawmills that do not comply with ADA Standards. Technical standards from the US Access Board are listed beside pictures as guidance for how items should be built or corrected in alterations and new construction.

The pedestrian right of way collector application covers each issue not complying with standards. The entire pedestrian network is mapped and addressed in the application. Sawmills' Public Works Department has access to this application and will correct issues in accordance with safety concerns, the Capital Improvement Program (CIP), and feasibility. Any corrected issue can be easily updated within the application to track improvements or technically infeasible items.

Farmers Market - US 321A & Sawmills School Rd





A

- » Pave parking area connecting to sidewalk.
- » Pave area for portion of farmers market and sidewalk with curb ramp connecting the parking area to pavilion.
- » Stripe parking area in front of sidewalk to prevent parking and blocking sidewalk access.
- » An accessible parking space that meets the dimensions of a van accessible space should be marked and signed on the paved parking portion



B

- » Sidewalk and curb ramps along Helena St connecting to existing sidewalk on Sawmills School Rd.
- » Option 2: Connect sidewalk from Helena St directly to paved area under pavilion.



C

- » Curb ramps are needed on both sides of Sawmills School Rd at the intersection of Helena St.
- » Detectable warnings are required for curb ramps leading pedestrians into roadways.

US 321A & Sawmills School Rd



A

B

C

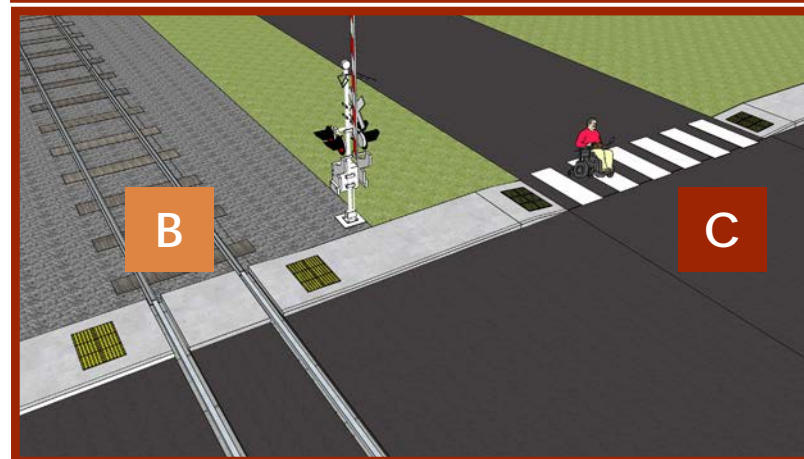
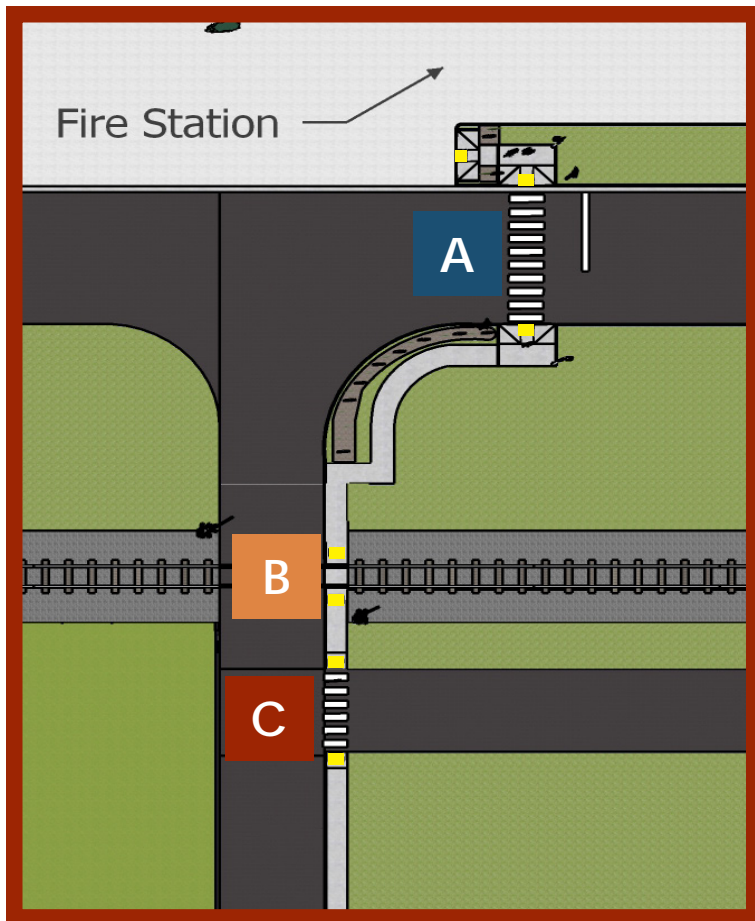

A » High visual crosswalk with compliant curb ramps, detectable warnings, and pedestrian signals are needed at both ends of crosswalk.

B » The pedestrian path must be at least 4 feet wide for the entire crossing. The surface between and on either side of the rails must be aligned with the top of the rails.

» The flangeway gap can be a maximum of 2.5 inches. Flangeway gaps can be 3 inches wide on freight rail tracks.

» A detectable warning (or truncated dome) must be located 6-15 feet from the centerline of the nearest rail. The detectable warning must extend the full width of the pedestrian crossing.

C » Convert crosswalk to a high visual crossing with compliant curb ramps and detectable warnings.

Sawmills Elementary School Entrance





- A » High visual crosswalk with compliant curb ramps, detectable warnings, and pedestrian signage are needed at both ends of crosswalk.

General Curb Ramp Improvements



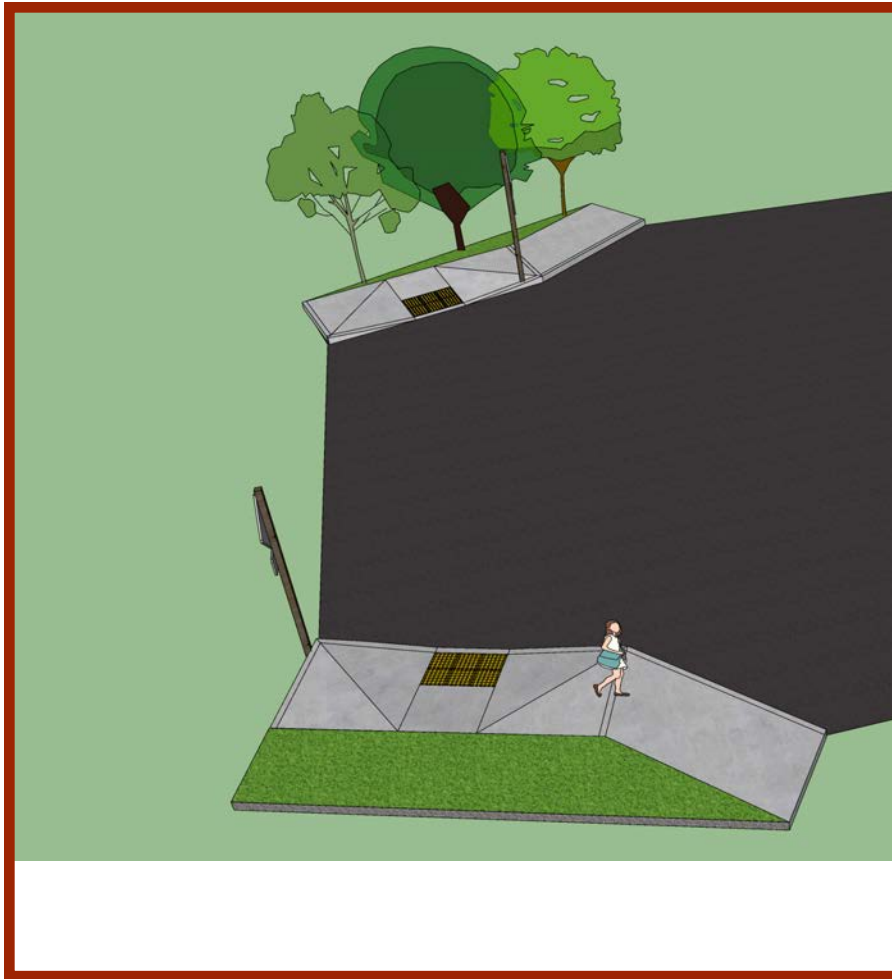

A

- » Compliant curb ramps with visually contrasting detectable warnings.
 - » curb ramp standards can be found in the *Technical Standards*.

Mission Rd & 321A



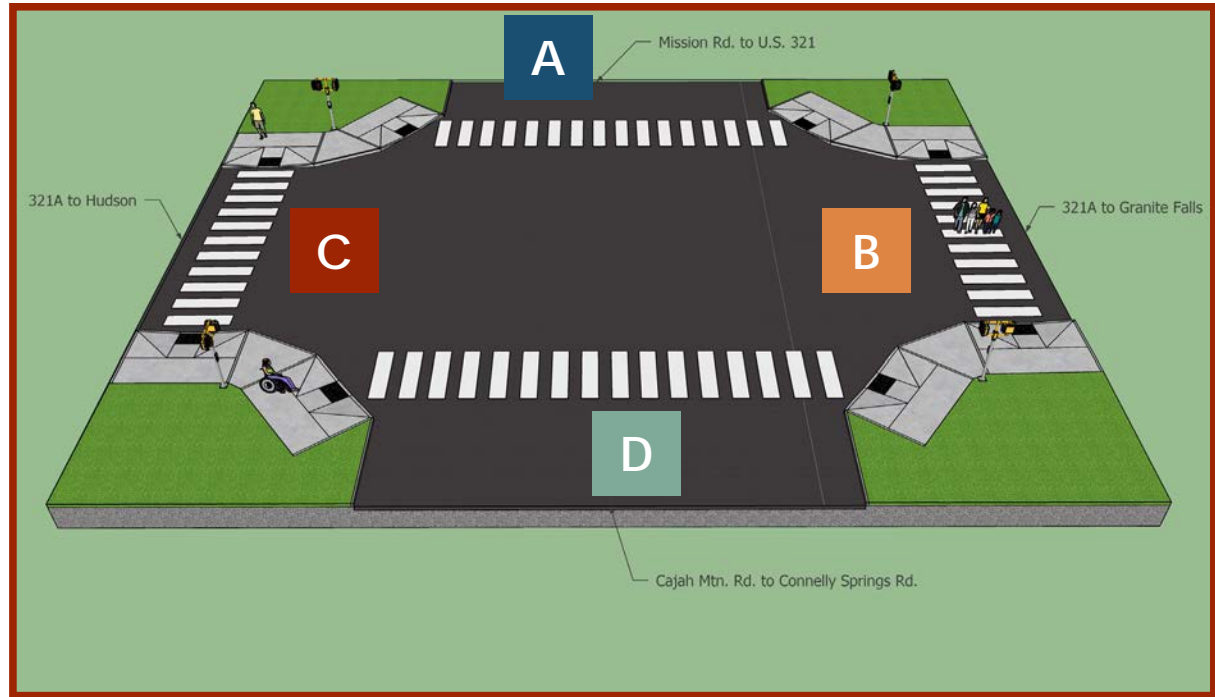
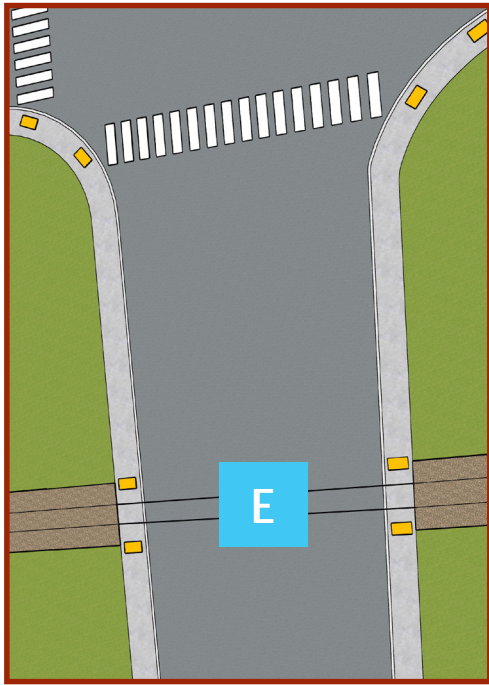

A

» Curb ramps are recommended at all four quadrants of the intersection.

B

» Add detectable warnings to all curb ramps (must visually contract against pavement).

C

» Install pedestrian signals at each quadrant of the intersection.

D

» Evaluate green times for traffic signals to ensure all pedestrians have sufficient crossing time.

E

» The pedestrian path must be at least 4 feet wide for the entire crossing. The surface between and on either side of the rails must be aligned with the top of the rails.

» The flangeway gap can be a maximum of 2.5 inches. Flangeway gaps can be 3 inches wide on freight rail tracks.

» A detectable warning (or truncated dome) must be located 6-15 feet from the centerline of the nearest rail. The detectable warning must extend the full width of the pedestrian crossing.

Mission Rd & Baird Dr Intersection

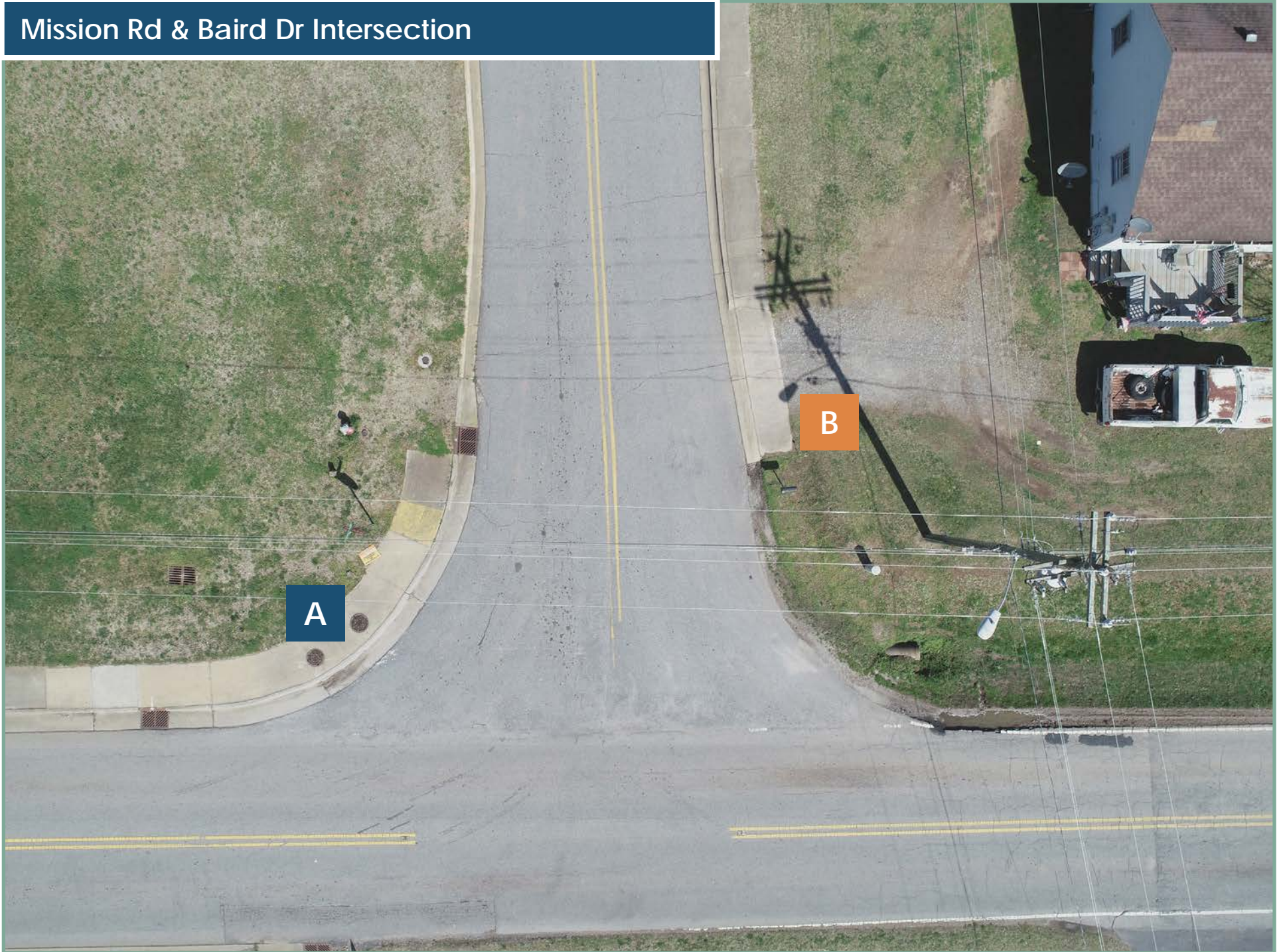

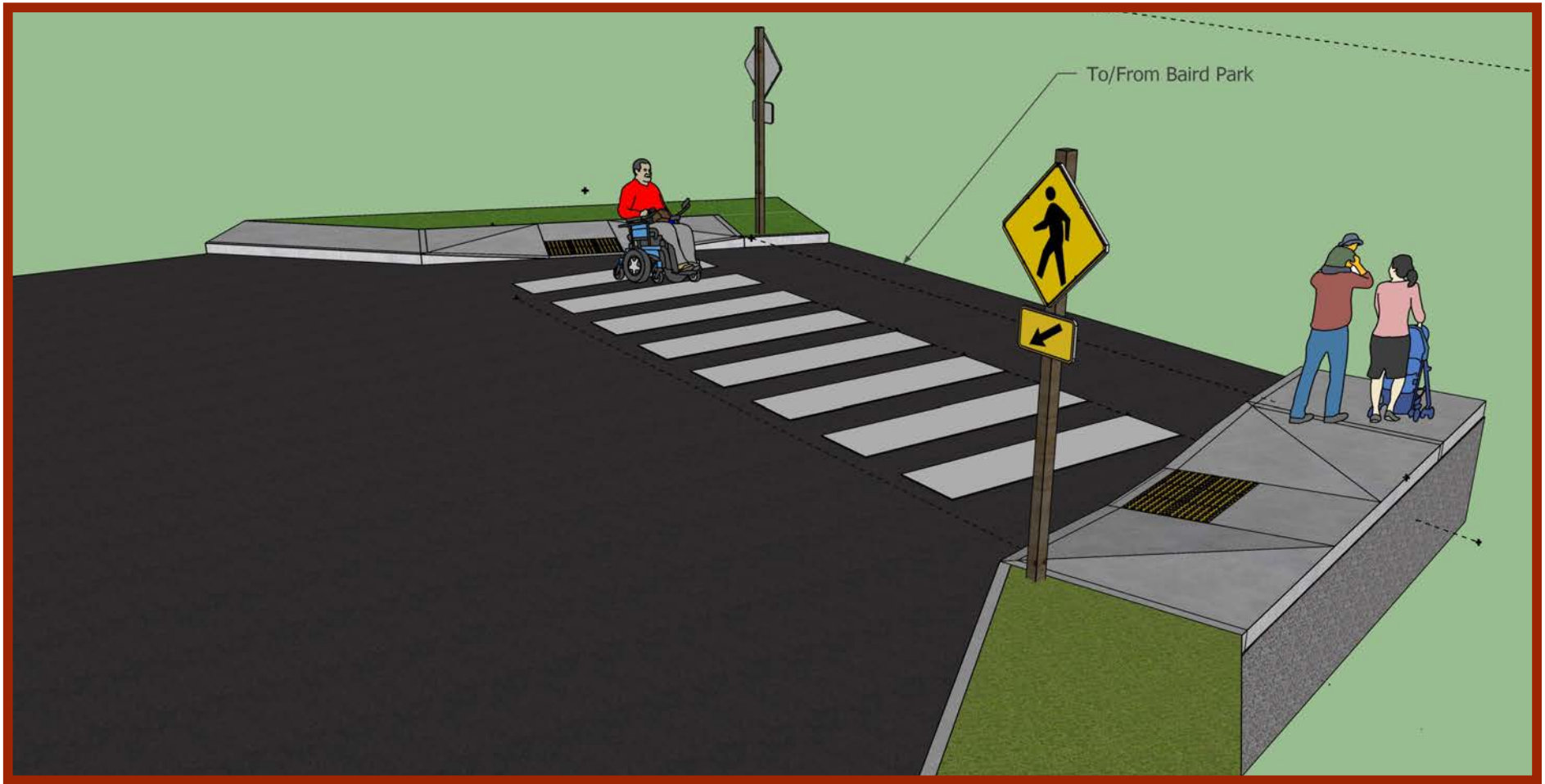

A » High visual crosswalk with compliant curb ramps, detectable warnings, and pedestrian signage are needed at both ends of crosswalk.

B » Sidewalk can not end in a driveway cut.
» Sidewalk should be extended down to the corner of the intersection and end in a curb ramp (as mentioned in Block A).

COST ESTIMATES

High and medium priority identified issues have been assigned cost estimates, if applicable. Labor has not been included in these estimates because the Town's maintenance staff plan to supply personnel to complete the labor. Dirt work (grading), acquisition, and engineering costs have not been included in the cost estimates. A majority of the projects that need this level of improvement are located within an NCDOT right of way and are/could be scheduled for improvement in the future. It is possible that right of way work will be contracted out through NCDOT's bidding process. Due to inflation, material cost and availability of personnel will fluctuate. These cost estimates should be reassessed at the time of implementation by an engineer and town staff.

General changes that are needed, either at no cost or minimal:

- Rearrange furniture to accommodate ADA requirements
- Remove obstacles that are impeding adequate movement.
- Adjust door pressures so the timing to close is compliant with ADA standards.
- Relocate or remove items as identified, such as hooks, dispensers, and fixtures that are protruding into the travel pathway

FACILITIES

(More ornamental signage can cost up to \$80 per sign) Standard signage has been evaluated.)



WHEELCHAIR SYMBOL LIFT SIGN FOR SPAS, SWIMMING POOLS, HOT TUBS, ETC.
(SIZE - 6" x 8")
\$84.95



ADA COMPLIANT WHEELCHAIR ACCESSIBLE EXIT SIGN
\$74.95



ADA WHEELCHAIR ACCESSIBLE EXIT SIGN WITH DIRECTION ARROW AND BRAILLE
\$84.95



NOT AN EXIT SIGN WITH NON-WHEELCHAIR ACCESSIBLE SYMBOL
\$30.95



PUSH TO EXIT SIGN WITH TACTILE TEXT AND BRAILLE - ADA COMPLIANT

\$39.95



WE ARE PLEASED TO PROVIDE ASSISTANCE FOR CUSTOMERS SIGN

(SIZE - 10" X 10")

\$54.95

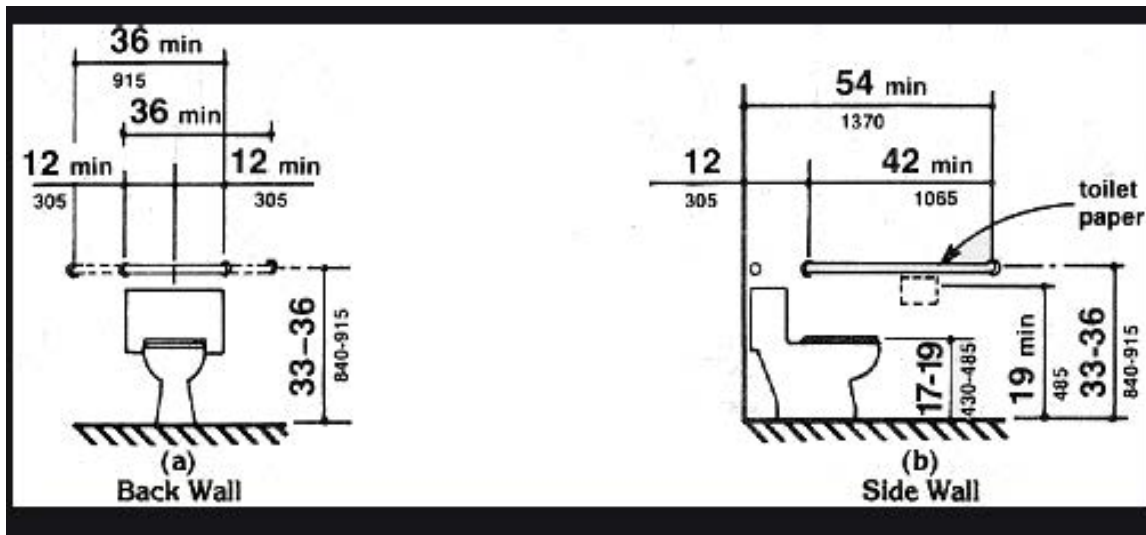

BRADLEY GRAB BARS - CONCEALED FLANGES (1 1/4")

(36" Long)

\$34.50



EMPLOYEES ONLY ROOM SIGN - ADA COMPLIANT TACTILE BRAILLE SIGNS

\$17.95



ADA COMPLIANT WHEELCHAIR ACCESSIBLE RESTROOM SIGNS

\$25.33 /per sign



AMERICAN SANITARY TOILET PARTITION SLIDE BOLT LATCH

\$8.60



KEENEY ADA COMPLIANT UNDER SINK SAFETY COVER KIT WITH OFFSET

\$37.76

(Insulation or piping replacement for sink ADA requirements - insulation noodle \$1.00 for 6 feet)

PARKING LOTS



R7-8B CALIFORNIA COMPLIANT VAN ACCESSIBLE HANDICAP PARKING SIGNS

\$14.95

(This sign can be added to the existing signs that are not posted correctly.)



U-CHANNEL POST

\$20.00



HANDICAP VAN ACCESSIBLE PARKING SIGNS

(SIZE - 12" x 18")

\$49.95

(This sign can be used where none exist and one is needed.)

PARKS

POURED PLAYGROUND RUBBER SURFACE – ADA

surface for playgrounds 1000 sq. ft. or larger can range from \$8 to \$14 per sq. ft. installed. For smaller playgrounds, the cost per square foot can be more expensive due to the minimum amount of raw material required. It is more cost effective to use rubber playground safety tiles in smaller play areas.

Generally, for wet poured rubber flooring, the surface area should be at least 1000 sq. ft. or more.

Rubber Safety Tiles for Playgrounds less than 1,000 sq. ft.

- 24" x 24" rubber tiles
- Available in both 2-1/2" and 4-1/4" thickness
- ADA compliant edges and accessories

PLAYGROUND SURFACING MATERIAL COMPARISON

As a general rule, unitary surfaces (with the exception of rubber tiles), tend to outperform loose fill materials on every criteria aside from the time and cost to install.

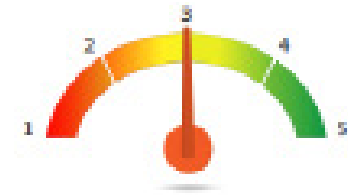

Material Type	Material	 Safety Certified	 Cleanliness	 Maintenance	 Accessibility	 Aesthetic	 Install Cost	 Lifetime Cost
Unitary	Synthetic Grass Systems							
Unitary	Poured in Place							
Unitary	Bonded Rubber							
Unitary	Rubber Nuggets							
Unitary	Rubber Tiles							
Loose-Fill	Engineered Wood Fiber							
Loose-Fill	Landscape Wood Mulch							
Loose-Fill	Sand							
Loose-Fill	Pea Gravel							

ASPHALT TRAIL FOR ADA ACCESSIBILITY (PARKS)

Asphalt paving costs \$7 to \$13 per square foot.

Reference for examples: www.americantrails.org/images/documents/TN-trail-ada.pdf

Crush Cinder Trails - Crusher fine trails usually cost in excess of \$10.00 per linear foot.

"Crushed stone trails provide a user-friendly, all-season surface for all types and ages of visitors, including strollers, wheelchairs, and road bikes."

Cost Range: \$1600 to \$4K (topography, utilities and amount of replacement required due to needed ADA slope are all factors)

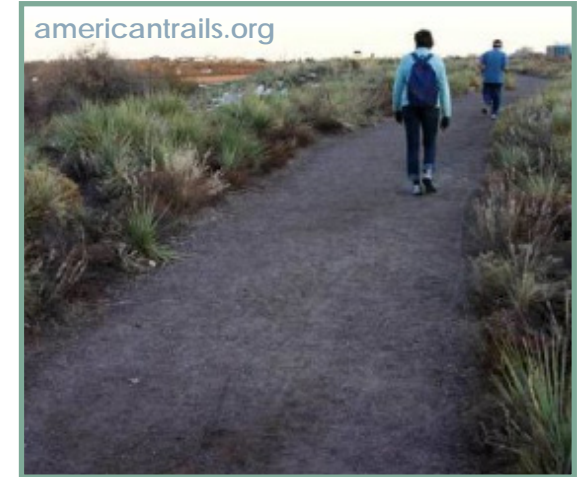

ADA HALF RAMP

\$533.00



ELEVATED SAND TABLE

\$2,131.00

Age Group - 2 to 5 years

Description:

- Rounded shape gives more children space to play
- Lipped edge keeps the sand in
- Raised to the perfect height to accommodate all children
- Sturdy legs placed at four points

Unit Cost of Surface Materials

Surfacing

loose fill materials	\$0.30 - \$1.30 per square foot, installed
engineered wood fiber	\$0.90 - \$3.20 per square foot, installed
rubber mats/tiles	\$6.35 - \$16.00 per square foot, installed, including underlayment
poured-in-place rubber	\$8.50 - \$21.00 per square foot, installed, including underlayment
transitions between loose fill and rubber materials	\$5.30 - \$11.00 per linear foot, installed
border materials	\$5.30 - \$16.00 per linear foot, installed

Unit Cost of Equipment Features

Accessible Equipment Features

12 inch rise of 1:12 ramp	\$1,484 - \$2,756
ramp landing	\$2,120 - \$5,512, including barriers
ramp and landing combined, per 12 inch rise	\$3,604 - \$8,218
transfer platform	\$424 - \$742
transfer platform with approach step	\$742 - \$1,590
transfer steps	\$106 - \$530 per foot of rise
earth berm to 24 inches	\$3,710 - \$5,830

Unit Cost of Other Items

Other Cost Elements

stairs	\$106 - \$265 per foot of rise
ladders and climbers	\$32 - \$159 per foot of rise
equipment installation	20% - 40% of equipment <u>cost</u>

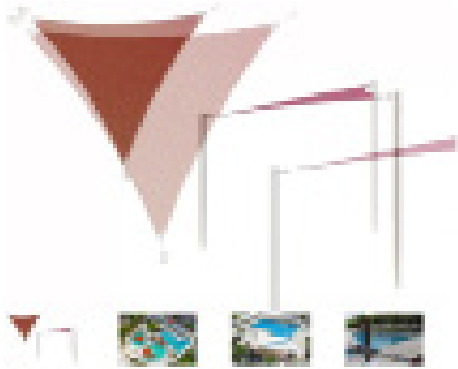

**EQUILATERAL TRIANGLE
FABRIC SAIL SHADE
STRUCTURE WITH 12FT.
ENTRY HEIGHT POWDER
COATED STEEL COLUMNS -
BASE MODEL**

(CANOPY SIZE - 15FT.)

\$5,099.95



**BENCH ATTACHMENT ARCH
FABRIC SHADE**

\$1,152.00

Range from 1100 to 6,000 depending on size, type of material and type of installation (footers, inspection, and engineering)

RIGHT OF WAY

New Sidewalk – 65.00 per linear foot (350,000 per mile)

Existing sidewalk repair - 20.00 per linear foot (100,000 per mile)

LEVELING -

The cost of leveling a slab usually ranges from \$500 to \$1,500. This is dependent on the size of the area to level, the materials used, and the labor involved. Foam leveling will likely cost around \$2,000-2,500 for a 100 square foot slab.

DETECTABLE WARNING SURFACE

Detectable warning surface is listed at \$424 per square yard. It was assumed that each curb ramp would be designed with the minimum necessary detectable warning surface necessary – 2' deep and as wide as the depressed area of curb, or 1.1 square yards for each detectable warning surface suggested.

LOW: \$475.00 each

HIGH: \$570.00 each

Stick-on detectable warning – \$200 to \$350

Set in concrete – \$290 to \$400



TRUNCATED DOMES ADA TILES - FOR CONCRETE SURFACES

(SIZE - 2' x 4')

\$223.37



TRUNCATED DOMES CAST-IN-PLACE REPLACEABLE TILE

(SIZE - 3' x 4')

\$389.00



TRUNCATED DOMES CAST-IN-PLACE REMOVABLE TILE

(SIZE - 3' x 5')

\$599.00

CONSTRUCT ADA-COMPLIANT CURB RAMP

Installing a new curb ramp at a corner is assumed to include the following: constructing a CG-12 with aggregate, a detectable warning surface, a 4' wide strip of concrete along the back of the ramp (about 10 square yards), 8 linear feet of new radial CG-6, sawcutting the existing pavement (about 22 LF), demolishing and then replacing a 1' strip of asphalt pavement along the new curb and curb ramp (about 22 LF), and 5 cubic yards of borrow for any grading that might be necessary behind the new ramp.

LOW: \$2,350.00 each

HIGH: \$2,820.00 each

Cost range due to topography, utilities and amount of replacement required due to needed ADA slope.

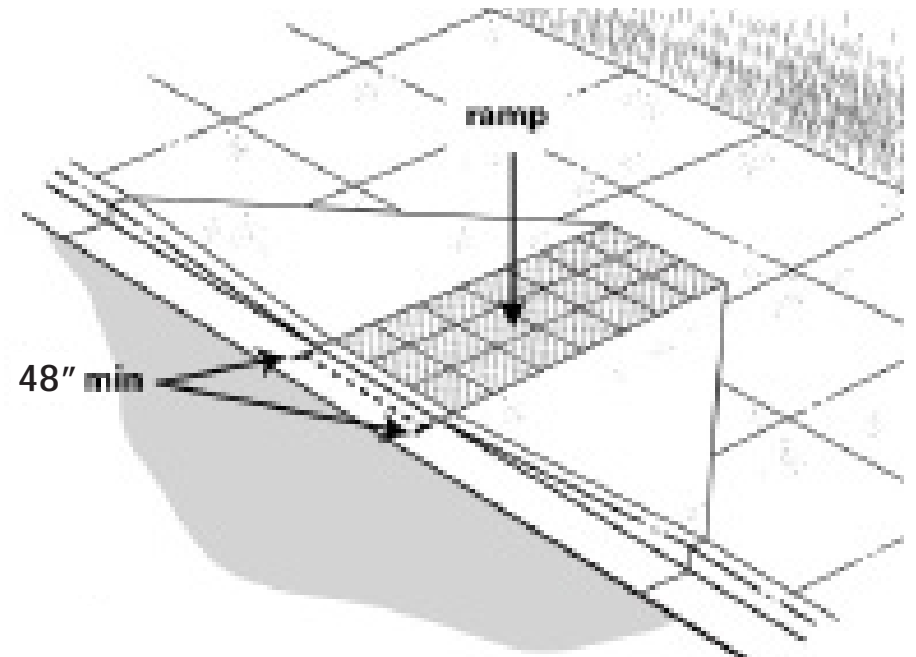

REPLACE EXISTING CURB RAMP WITH ADA-COMPLIANT CURB RAMP

Replacing a curb ramp is assumed to involve the following actions: removing the existing concrete curb ramp (assumed to be 12 SY), removing 4 feet of concrete sidewalk along the back of the ramp for grading purposes (about 10 square yards), and installing a new curb ramp.

LOW: \$3,200.00 each

HIGH: \$3,840.00 each

INSTALL CURB AND GUTTER

The installation of curb and gutter includes the costs of sawcutting asphalt pavement, removing a 1' wide strip of existing asphalt pavement, installing a 1' wide strip of full depth asphalt pavement, the cost of the combination concrete curb and gutter itself, and grading behind the curb.

LOW: \$43.00 per linear foot

HIGH: \$51.60 per linear foot

FULL-DEPTH ASPHALT PAVEMENT (TRAIL)

Full depth asphalt pavement is assumed to be 2" of surface course, 4" of intermediate course, 6" of base course, and 8" of aggregate.

LOW: \$101.00 per square yard

HIGH: \$121.20 per square yard

MILL AND OVERLAY (REMOVING, SEALING AND RE-POURING ASPHALT)

Mill and Overlay consists of milling the top layer of flexible pavement and installing a 2" thick overlay on top. The 2" surface course is \$13.03 per SY. Type A Milling (1 ½" depth) is listed at \$30.92 in the Statewide Averages.

LOW: \$49.00 per square yard

HIGH: \$58.80 per square yard

INSTALL BUS STOP PAD

The cost of installing a bus stop pad was based on cost estimates for a group of 11 Fairfax County Bus stops designed by Kimley-Horn. These bus stop pads did not include shelters, and about half included benches. The five most expensive bus stop pads were averaged to produce the "high" cost and six least expensive were averaged to produce the "low" cost. These costs reflect only the construction costs associated with the construction of the bus stop pad and do not include mobilization, maintenance of traffic, utility relocations, professional engineering services, surveys, production of plats, or any contingencies.

LOW: \$5,000.00 each

HIGH: \$9,200.00 each

DEMOLITION OF ASPHALT PAVEMENT

Demolition of flexible pavement is listed at \$10.68 per SY.

LOW: \$11.00 per square yard

HIGH: \$13.20 per square yard

CURBED SIDEWALK

Curbed sidewalk is bid as curb-abutted sidewalk with no buffer space.

LOW: \$63.00 per linear foot

HIGH: \$75.60 per linear foot

DEMOLISH CONCRETE MEDIAN NOSE

This item includes the demolition of 5 linear foot of concrete median nose, replacing that space with full-depth pavement, and relocating the sign that was in the median nose. The cost for demolishing the median nose is assumed to be the same as demolition of curb and gutter, which is listed at \$18.10.

LOW: \$1,600.00 each

HIGH: \$1,920.00 each

RELOCATE PEDESTRIAN SIGNAL POLE

Relocating a pedestrian signal pole requires the removal and disposal of the existing pedestal pole and associated push buttons, signs, signal heads, wiring, and junction boxes. The total cost of these items is \$2,650 as derived from previous project experience. The new pole requires a PF-2 Pole and PF-2 Pole Foundation, 500 linear foot of both 14 AWG/7C and 14 AWG/2C conductor cable, a push button with associated sign, and a LED pedestrian signal head. The cost for the PF-2 Pole and foundation is a combined \$1,570. The cost for the conductor cables, push button and sign, and a pedestrian LED Signal Head is a combined \$5,665 as derived from previous project experience.

LOW: \$10,000.00 each

HIGH: \$12,000.00 each

NEW PEDESTRIAN SIGNAL POLE

The new pole requires a PF-2 Pole and PF-2 Pole Foundation, 500 linear foot of both 14 AWG/7C and 14 AWG/2C conductor cable, a push button with associated sign, a LED pedestrian signal head, and a new junction box. The cost for the PF-2 Pole and foundation is a combined \$1,570. The cost for the conductor cables, push button and sign, a pedestrian LED Signal Head, and new junction box is a combined \$6,125 as derived from previous project experience.

LOW: \$7,800.00 each

HIGH: \$9,360.00 each

UPDATE SIGNAL DISPLAY

Updating a signal display requires a new 3-Section Signal Head, 500' of 14AWG/7C conductor cable, and removing and disposing of the existing signal heads. From past projects, we've estimated this cost at \$2,300 per updated signal head.

LOW: \$2,300.00 per updated signal head

HIGH: \$2,760.00 per updated signal head

IMPLEMENT SPLIT PHASE OPERATIONS

Implementing split phase operations is assumed to include the installation of a new 4-Section Signal Head, 500 linear foot of 14AWG/7C, a new elongated double arrow, and the removal of existing signal head for each approach. Implementing split phase operations assumes doing this to both sides of an approach, so costs are doubled.

LOW: \$7,300.00 per pair of approaches

HIGH: \$8,760.00 per pair of approaches

FLASHING SIGNAL BEACON

It is assumed that flashing signal beacons will be hard-wired to the signal cabinet. Each pair of flashing signal beacons includes signs, beacons, poles, foundations, conduit, conductor cable, and junction boxes. Based on prior project experience, the combined cost of these items will be \$15,000.

LOW: \$15,000.00 per pair

HIGH: \$18,000.00 per pair

STRIPING

4" pavement markings are listed at \$0.61 per linear foot

LOW: \$0.61 per linear foot

HIGH: \$0.73 per linear foot

RE-STRIPING

Re-stripping a road requires both eradicating pavement markings and laying down new pavement markings. Eradicating pavement markings is listed at \$0.53 per linear foot averages, and 4" pavement markings are listed at \$0.61 per linear foot.

LOW: \$1.14 per linear foot

HIGH: \$1.37 per linear foot

STRIPING FOR TURN LANE

Striping for a turn lane is assumed to include three elongated single turn arrows, and two "ONLY" pavement markings.

LOW: \$950.00 per turn lane

HIGH: \$1,140.00 per turn lane

ELONGATED ARROW

Elongated single arrows are listed at \$107.73 each

LOW: \$110.00 each

HIGH: \$132.00 each

ELONGATED DOUBLE ARROW

Elongated double arrows are listed at \$152.20 each

LOW: \$160.00 each

HIGH: \$192.00 each

STOP BAR

24" Type B Class IV Pavement Markings at \$16.05 per linear foot.

LOW: \$16.00 per linear foot

HIGH: \$19.20 per linear foot



**30" PUSH BUTTON LED
FLASHING CROSSWALK
SYSTEM**

\$4,399.99



**SOLAR HORIZONTAL
RAPID FLASHING
BEACON SYSTEM BACK
TO BACK WITH PUSH
BUTTON ACTIVATION**

\$3,499.99

LED lighting solutions

PUBLIC COMMENTS

No public comments were received for this Plan.

APPENDIX

Appendix A: ADA Checklist for Existing Facilities - www.adachecklist.org/doc/fullchecklist/ada-checklist.pdf

Appendix B: ADA Checklist for Existing Facilities - Play Areas - www.adachecklist.org/doc/rec/play/play.pdf

Appendix C: Compliant Surfaces from September Report -

1. <https://www.access-board.gov/ada/guides/chapter-3-floor-and-ground-surfaces/>
2. <https://inspectionsada.com/ada-compliance-blog/2020/12/15/play-area-ground-surfaces-and-the-ada-p82zm>
3. <https://ncaonline.org/nca-publishes-results-of-trail-surfaces-study/>
4. www.access-board.gov/research/completed-research/improved-engineered-wood-fiber-ewf-surfaces
5. www.access-board.gov/guidelines-and-standards/recreation-facilities/guides/surfacing-the-accessible-playground
6. www.ncaonline.org/resources/articles/playground-surfacestudy-finalreport.shtml